

/

•

SK Corporation

2005. 10. 21

. SK Corporation

. SK Corporation 가

. SK Corporation 가

. SK Corporation

SK Corporation

가

Globalized Innovative Marketing Company

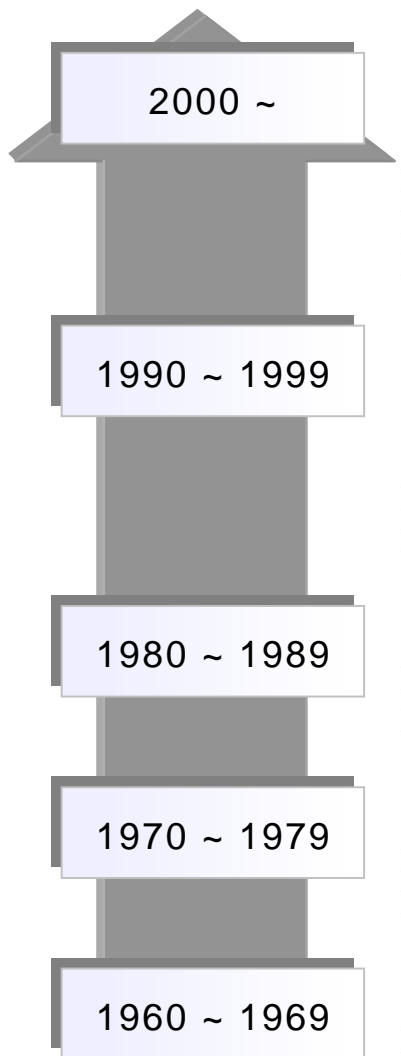

가

&

Network

- 4/5 가 (265/200), 1/2 가 (30/50)
- (73), 1/2 가 (345/320)
- 2 가 (400), 2 가 (400)
- 3 가 (170)
- 1 가 (216), 1 가 (100)
- 1/2 가 (35/60)

. SK Corporation

Energy

/ Trading,

/

가

- /가 /

Energy

가

Portfolio

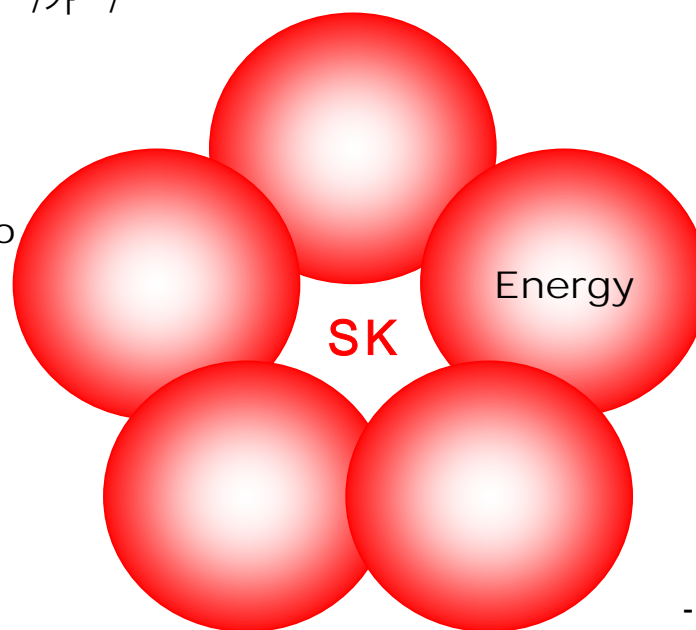

Energy

-

Energy

-

- Portfolio

가

SK

R&D

-

&

-

Service

- Nate Drive
- OK Cashbag

. SK Corporation

. SK Corporation 가

. SK Corporation 가

. SK Corporation

SK Corporation 가

가
가

• Major /

가

/ /

SK Corporation
가

/

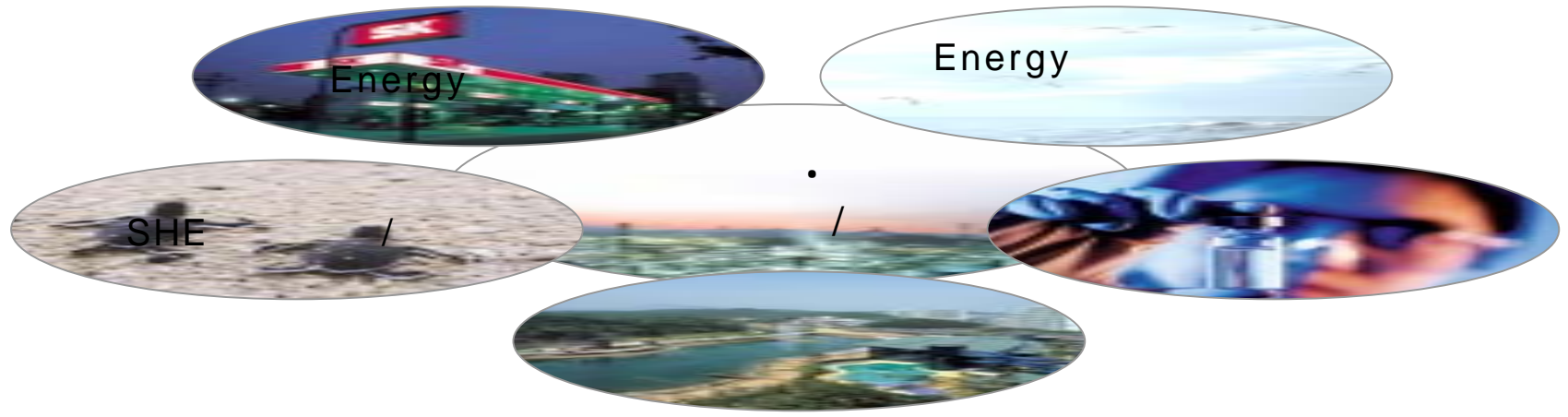

) SHE : Safety, Health, Environment

SK Corporation 가

가

SK

SK

가

가

World Best

Total Solution

Brand

가

Major

➤ Energy

➤ Energy

➤ SHE /

➤

➤

. SK Corporation

. SK Corporation 가

. SK Corporation 가

. SK Corporation

가
SHE (Safety, Health,
Environment)

SHE (Safety, Health,
Environment)

SHE

가

SHE

가

SHE

➤ / SHE

- 2 SHE 가

- SHE 가

- , 가

➤ /

➤ SK Corporation

	85%
	50%
	Major (BP)

SHE (Safety, Health, Environment)

SK 가

Safety

Health

-
-
-
-

-
-
-

50%

SHE

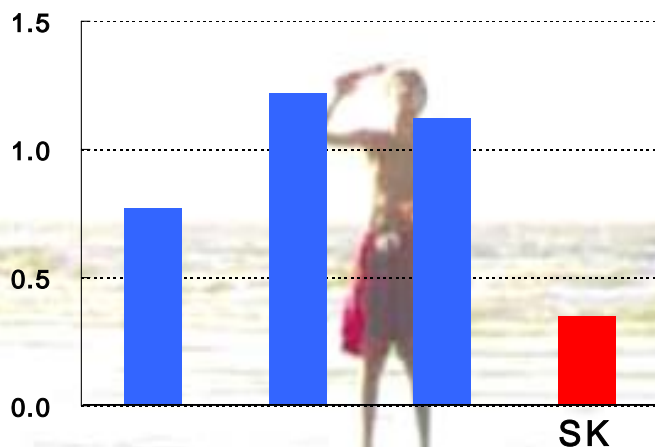

Source : '02 11 2 2005



Environment

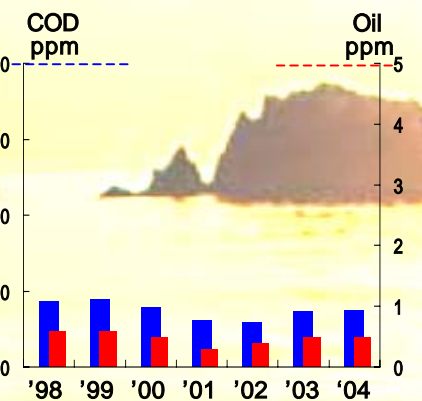
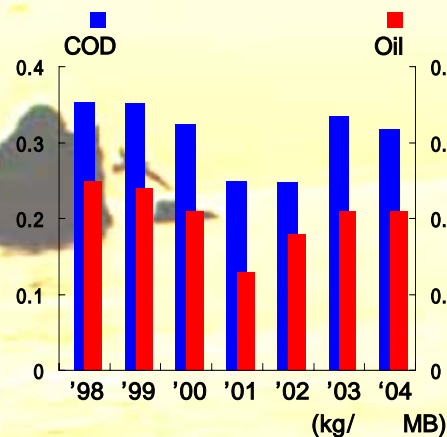
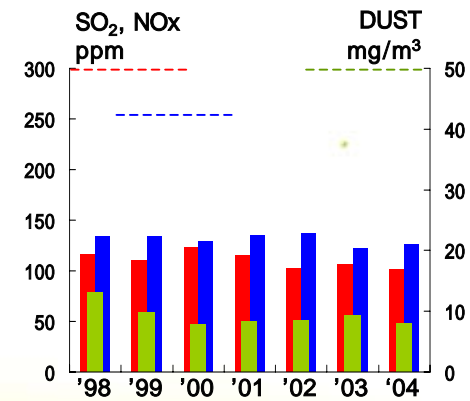
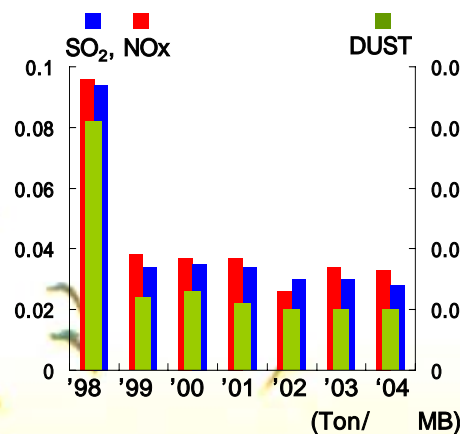
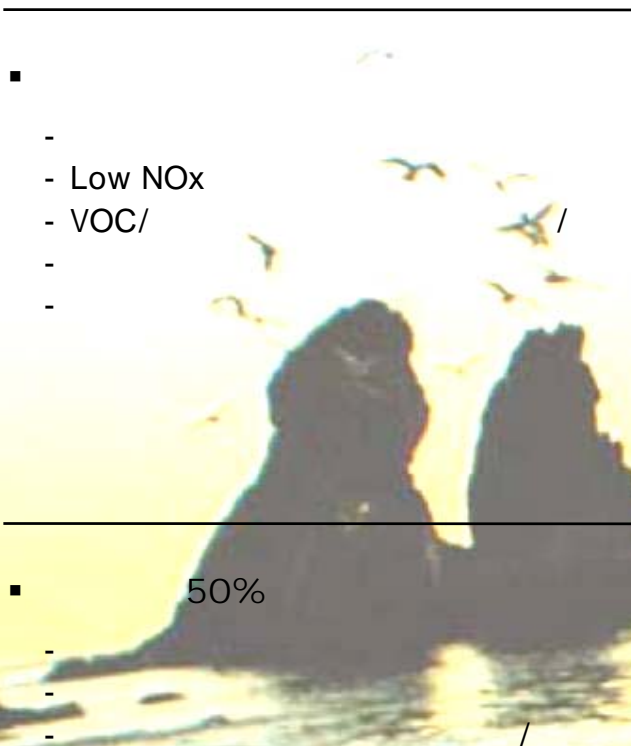

SK Corporation 가

가

Energy

가 / Energy

➤ 2000

- Energy CO₂ 5
- 6%, 14% CO₂

/

➤

- 가

-

/

➤

- Monitoring, Verification

➤

/

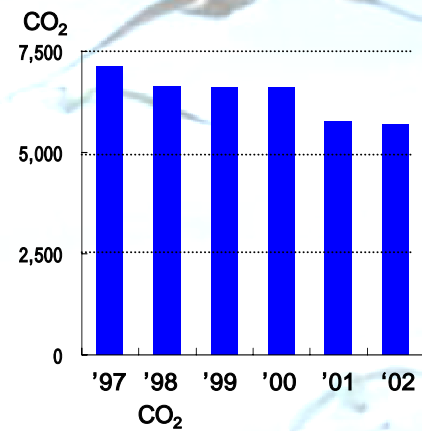
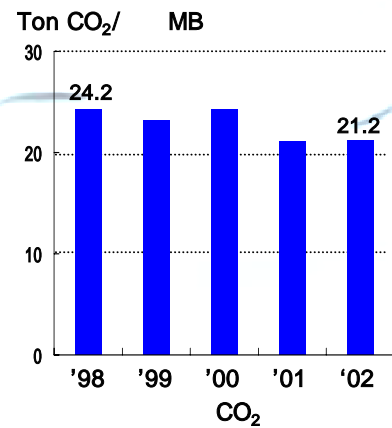

SK Corporation 가

Energy Energy

Energy

Energy 가 가 /

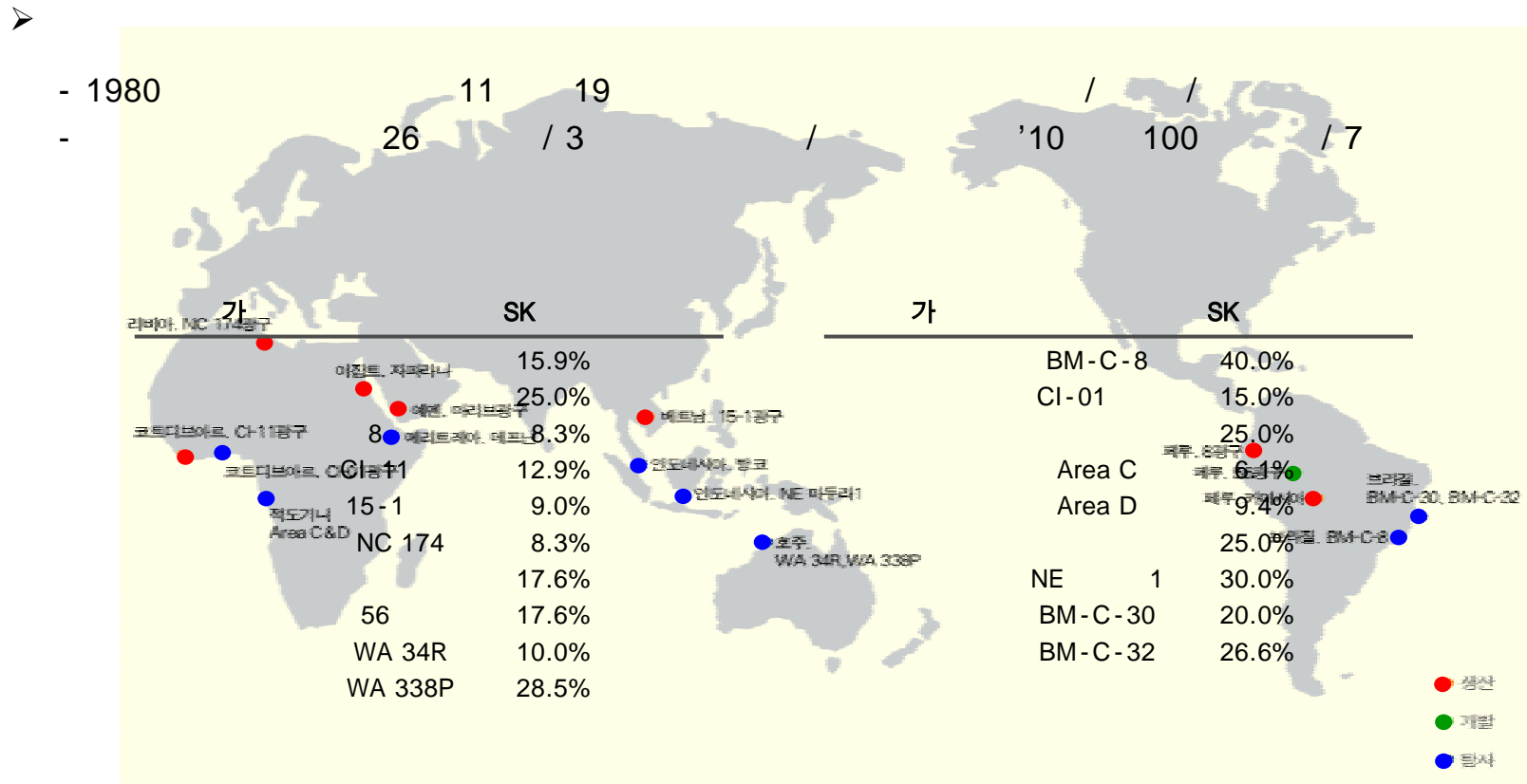

Energy _

➤ 가

- LNG Project 4
- LNG

가	(/)	
Qatar	2.6	
Oman	5.3	
Yemen	46	, '08
Peru	270	, '09



➤

- 1990 3

SK	(/)	()
15.0%	250	79
5.0%	100	32
25.0%	300	101

- 2 Project

SK	(/)	()
가	8.3%	500 211
	4.3%	500 187
		()

-
-

Energy

Energy

Know-how

Energy

Energy /

ESC0 (Energy Service Company)

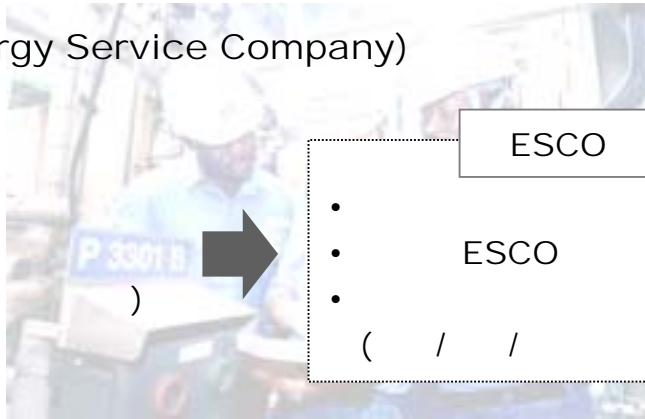

Energy

가 (Landfill Gas)

- 가 ()
- 49 LNG
- 21 LFG
- 가

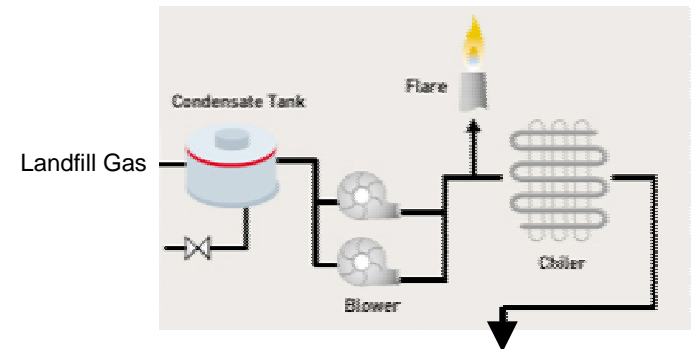

SK Corporation 가



가

가

Energy /

➤

(Fuel Cell)

-
-
-

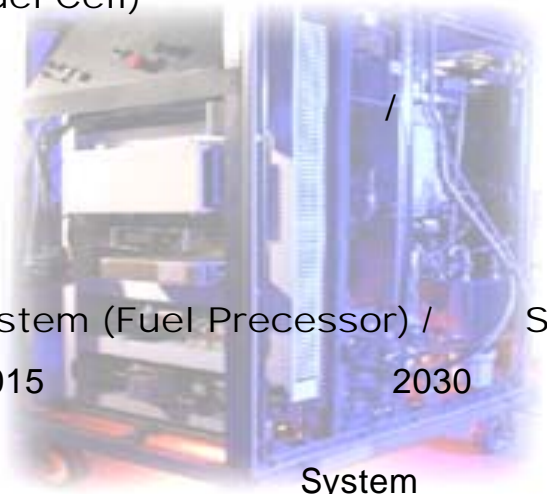

Energy

➤

System (Fuel Processor) /

- HEV 2015 40%
- HEV

Station

System

Station

- 2002 25KW System
- 가 System
- 2007 Demo Station
- LPG Station System

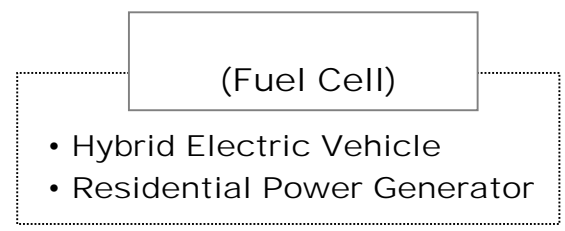

Station

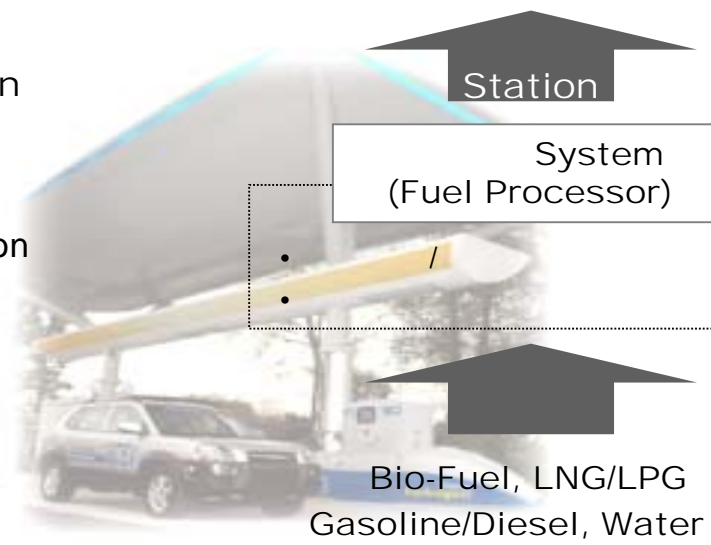

Bio-Fuel, LNG/LPG
Gasoline/Diesel, Water

SK Corporation 가



▶ LIBS (Lithium Ion Battery Separator)

- HEV
- Lithium Ion Battery 가 , Polymer
- LiBS ,
- HEV Battery Packaging

Battery 가
가 2
LiBS 가



▶ (Community Energy System)

- /
- 35%
- 70~80%
- 8 APT
- CES



▶ Bio-Diesel

- , Bio-Diesel 가 가 가
- Energy 가



Energy

➤ CNC (Catalytic Naphtha Cracking)

- Naphtha
- Naphtha
- CO₂ / Yield 가
- (Lab Scale Test)

Energy

➤ APU (Advanced Py-gas Upgrading)

- Naphtha Py-gas
- BTX LPG
- 가 BTX 가
- Axens ,

➤ ATA (Advanced Transalkylation)

- Naphtha C9 Aromatics
- Benzene / Xylene
- GS Caltex, Formosa, Reliance ,

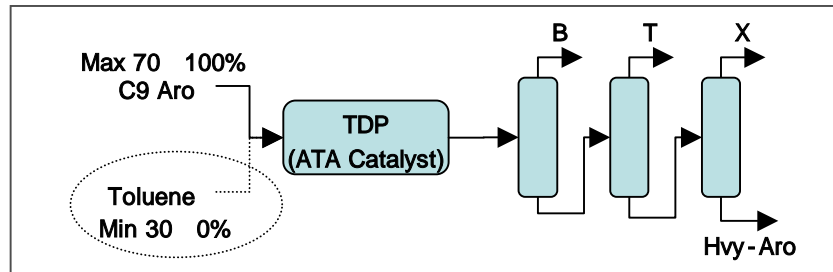
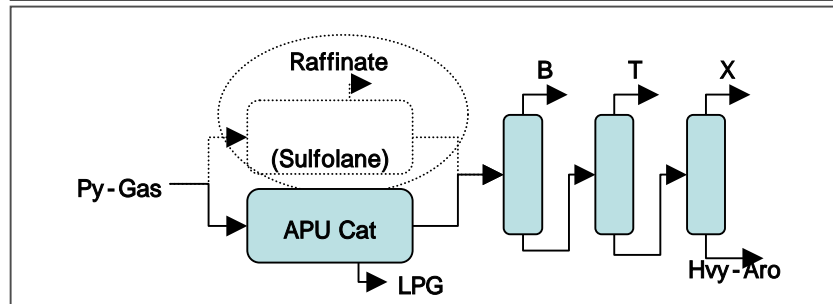
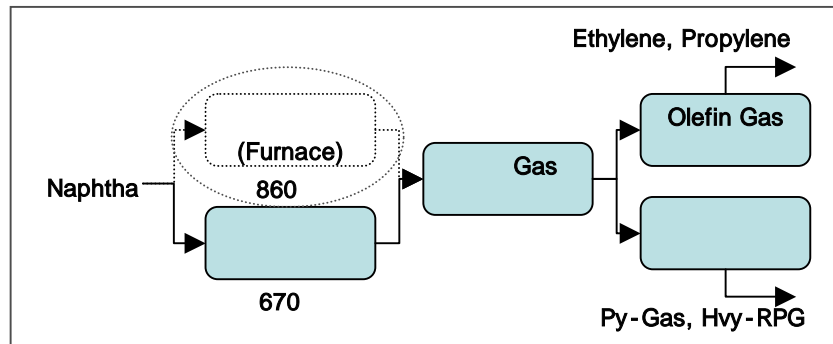

SK Corporation 가



Energy

➤ SCR (Selective Catalytic Reduction)

- , (NOx)
- 90% NOx
- 4

➤ VOC (Volatile Organic Compound)

- / Tank
- (VOC), 95%
-

- 가 ,
- (Particular Matter 90%))
- 20 km Test , /

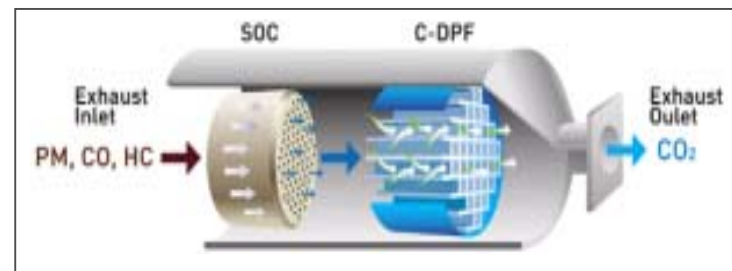
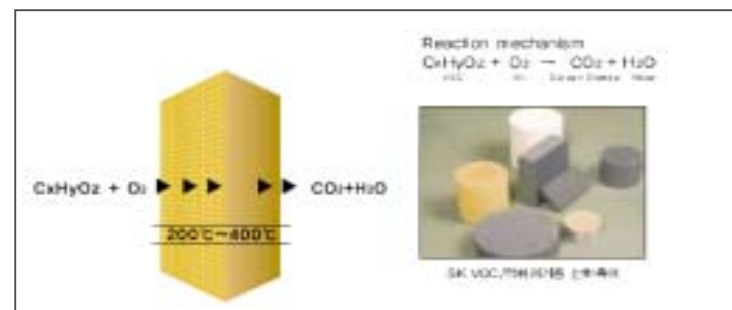
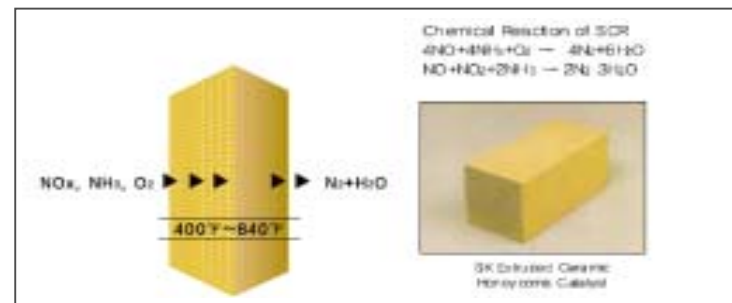

SK Corporation 가

/ /

SK 1004



- 110 1996 10
 - 2002 4 1 2005 12

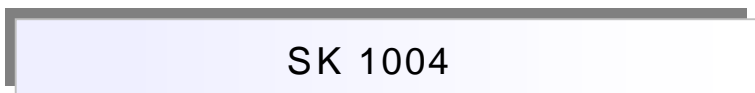

30% 1,500



40 / /

- : / / 가 ,
 : / , () ,
 : , / 가

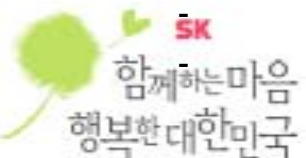

- . SK Corporation
- . SK Corporation 가
- . SK Corporation 가
- . SK Corporation

SK Corporation

SK Corporation

•

Major

/

.

SK Corporation

•

Major



Energy



SHE

/



End of Document

