

Introduction to Separation Processes

What is Separation and Separation Processes ?

- Separate (definition from a dictionary)
 - to isolate from a mixture; [extract]
 - to divide into constituent parts

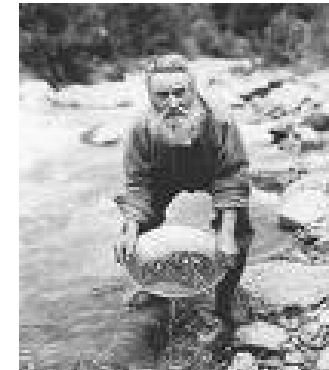

- Separation process
 - In chemistry and chemical engineering, a separation process is used to transform a **mixture** of substances into two or more **distinct products**.
 - The specific separation design may vary depending on what chemicals are being separated, but the basic design principles for a given separation method are always the same.

Separations

- Separations includes
 - Enrichment
 - Purification
 - Isolation
 - Concentration
 - Refining
- Separations are important to chemist & chemical engineers
 - Chemist : analytical separation methods, small-scale preparative separation techniques
 - Chemical engineers : economical, large scale separation methods

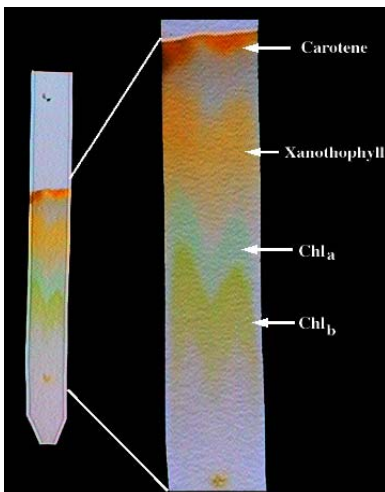

Why Separation Processes are Important ?

- Almost every element or compound is found naturally in an impure state such as a mixture of two or more substances. Many times the need to separate it into its individual components arises.
- A typical chemical plant is a chemical reactor surrounded by **separators**.

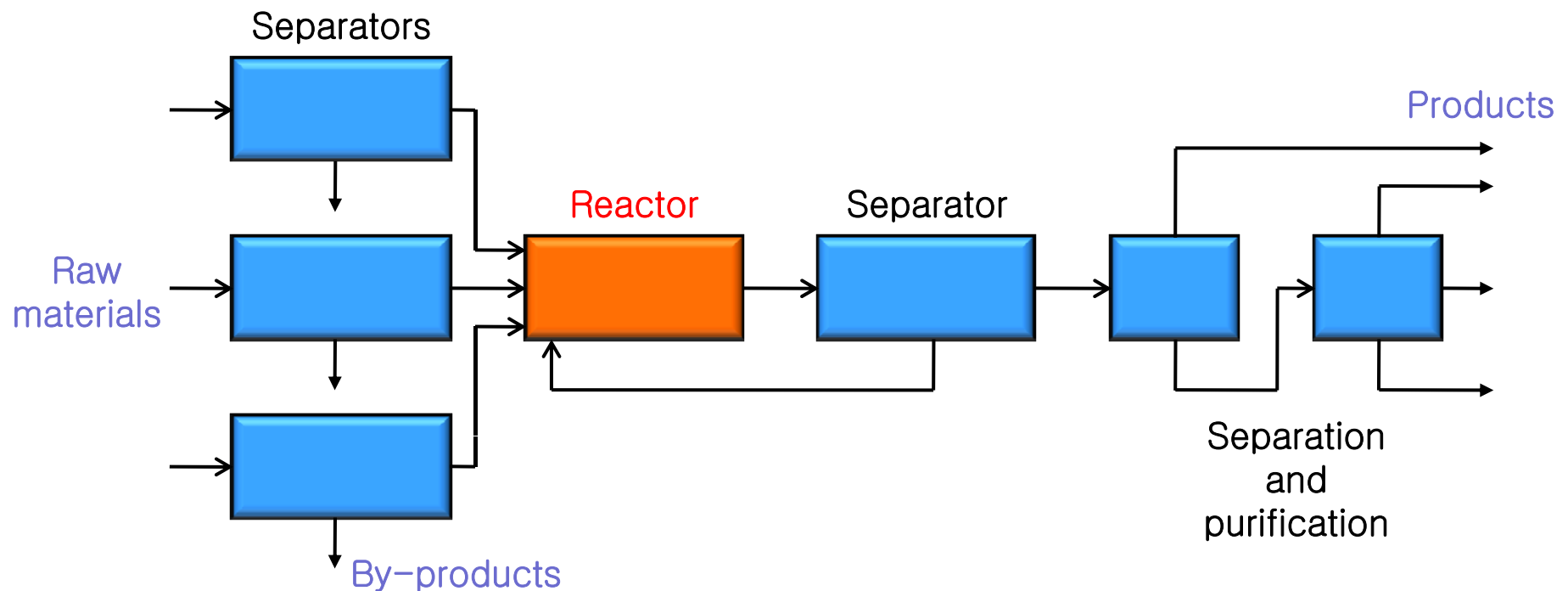

- Chemical plants commonly have 50–90% of their capital invested in separation equipments.

Why Separation is Difficult to Occur?

- Second law of thermodynamics
 - Substances are tend to mix together naturally and spontaneously
 - All natural processes take place to increase the entropy, or randomness, of the universe
 - To separate a mixture of species into products of different composition, we must supply the equivalent of energy (heat or work)

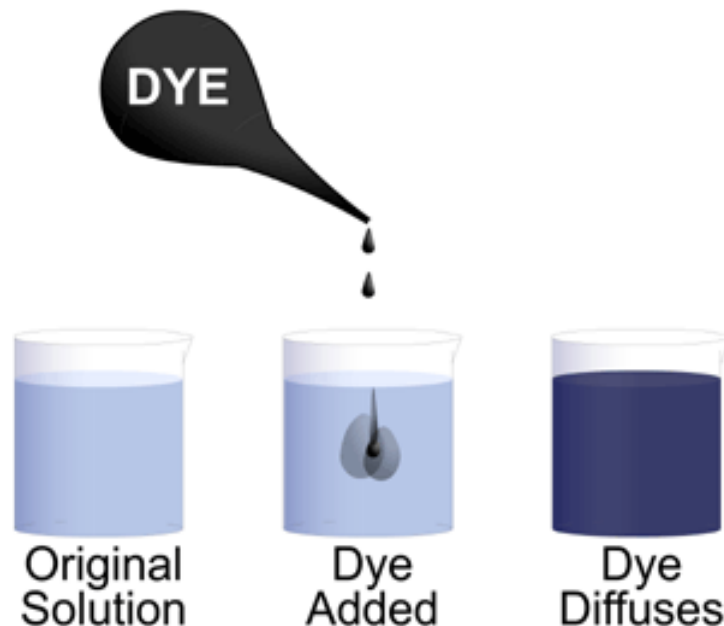

How Separations are Achieved?

- Enhancing the mass transfer rate of certain species
- Rate of Separation : **how fast ?**
 - Governed by **mass transfer** (Rate-controlled separation)
- Extent of Separation : **how far ?**
 - Limited by **thermodynamics** (Equilibrium-staged separation)
- Properties of Importance

Molecular Properties	Thermodynamic and Transport Properties
Molecular weight	Vapor pressure
van der Waals volume	Solubility
van der Waals area	Adsorptivity
Molecular shape (Acentric factor)	Diffusivity
Dipole moment	
Polarizability	
Dielectric constant	
Electric charge	
Radius of gyration	

Data sources: Handbooks, journals, electronic databases, commercial process simulators

General Separation Techniques

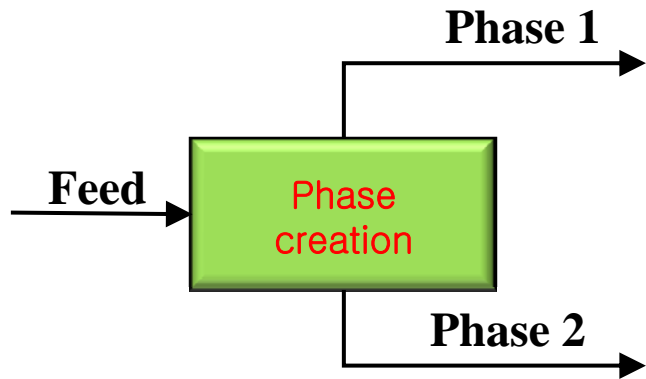

(a) By phase creation

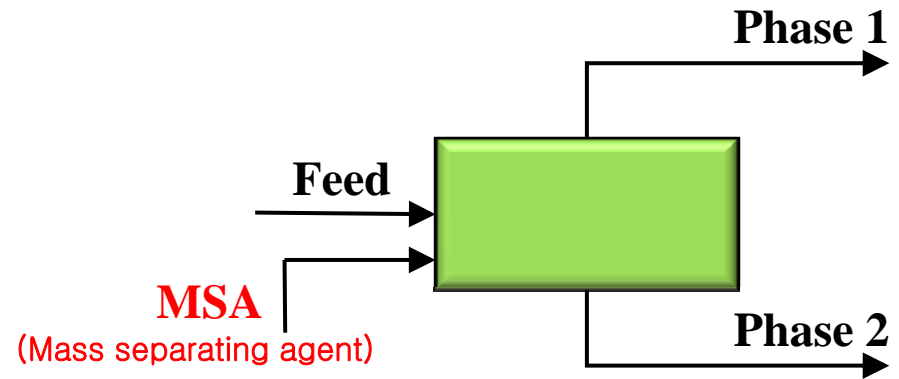

(b) By phase addition

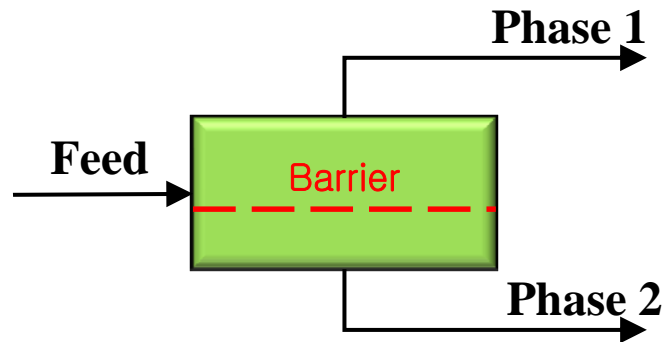

(c) By barrier

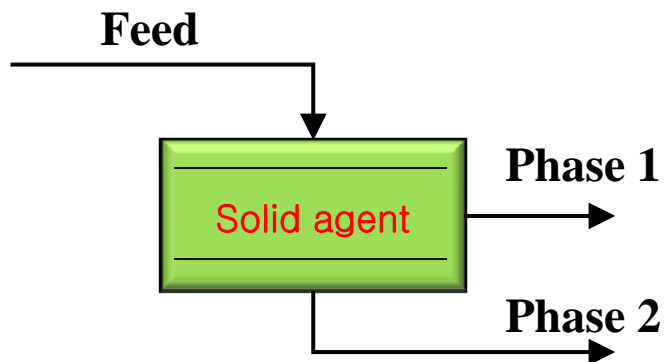

(d) By solid agent

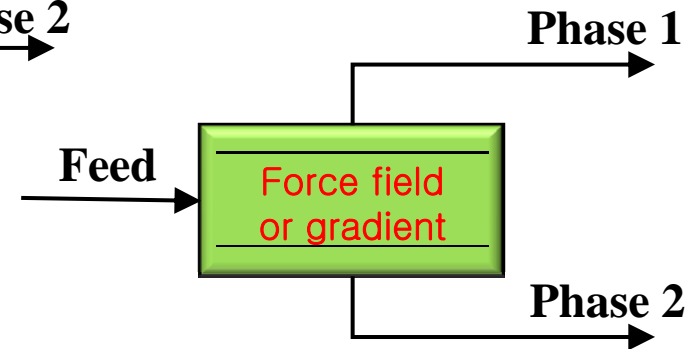

(e) By force field or gradient

Which Separation Process Will You Choose?

- There are numerous approaches for separation.



- (1) Supply heat and boil water off, condensing the water at a lower temperature.
 - (2) Supply refrigeration and freeze out pure ice, melting the ice at a higher temperature.
 - (3) Pump the water to a higher pressure and force it through a thin solid membrane.
- ⇒ Consider product requirement, cost, environmental effects, etc.