

Retrofitting Conventional Column Systems to Dividing Wall Column for Debottlenecking

Nguyen Van Duc Long and Moonyong Lee*

School of Chemical Engineering and Technology, Yeungnam University
(mynlee@yu.ac.kr*)

1. Introduction

It is well-known that distillation plays an important role in producing products in chemical process industries. It consumes the largest energy among process units with estimated 3% of world's energy consumption [1]. One of the hottest issues nowadays associated with distillation is to develop a new type of column and/or enhance the performance of existing distillation processes for more energy efficiency.

Dividing wall column (DWC), schematically drawn in Figure 1, is rapidly applied in a variety of chemical processes because of its potentiality in energy and capital cost saving for separation of multicomponents. The main objective in this work is to investigate the using of DWC for removing the bottleneck phenomenon in the column when increasing the throughput of an existing distillation process; particularly, acetic acid (AA) purification process.

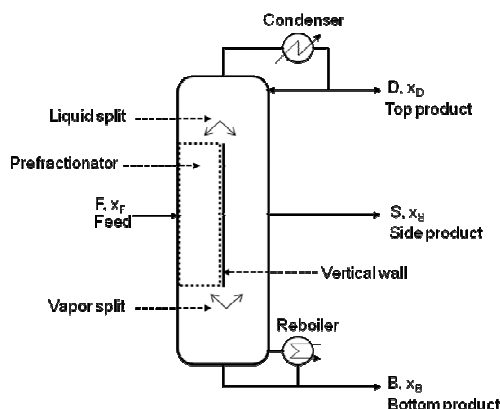

Figure 1. A schematic diagram of the dividing wall column.

2. Existing process

2.1. Existing process configuration

Acetic acid (AA) is an important industrial commodity chemical, with a world demand of about 6 million tonnes per year and many industrial uses [2]. The proffered industrial method for its manufacture is by the carbonylation of methanol and this accounts for approximately 60 percent of the total world acetic acid manufacturing capacity. A mixture of crude acetic acid and contaminants is distilled in a series of columns [3]. Figure 2 illustrates the existing distillation columns sequence and its current operating conditions. Table 1 presents the conditions and product specifications for each column in the existing columns sequence. From the base case simulation model, it shows that the energy consumption of three columns are 17.39, 13.05 and 19.06 Gcal/hr, respectively.

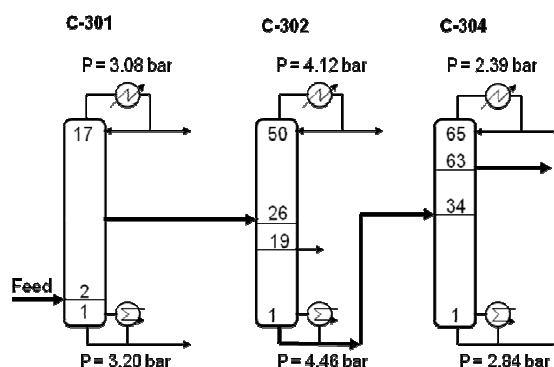

Figure 2. A simplified flow sheet illustrates the existing separation train showing three of columns.

2.2. Existing column hydraulics

Column hydraulic as well as flooding, which is normally caused by entrainment flooding and downcomer backup in valve-trayed column, have to be considered. When downcomer is small or downcomer backup is high, downcomer flooding is appeared, which causes liquid accumulation on the tray above; while the entrainment is caused by rising of vapor velocity. To determine the max flooding of a particular column, rating mode is simulated with column internal specifications such as type of trays, column diameter, tray spacing, and number of passes, etc. Table 1 lists parameters which are necessary to define the existing hydraulic features of the columns. All columns were designed with the maximum flooding being around 85% to prevent the flooding occurring in the columns.

Table 1. Column hydraulics, energy performance and product specifications of the existing columns sequence

	C-301	C-302	C-304
Number of trays	17	50	65
Tray type	Valve	Valve	Valve
Column diameter (m)	4.4	3.0	3.8
Number of flow paths	1	1	1
Tray spacing (mm)	609.6	457	457
Max flooding (%)	85.95	84.26	87.03
Condenser duty (Gcal/hr)	49.26	25.71	20.01
Reboiler duty (Gcal/hr)	17.39	13.05	19.06
Recovery of acetic acid (%)	65.41	80.17	88.77
Purity of acetic acid (%)	82.50	98.92	99.92
FA amount in final product stream (ppm)	580 (<1000 ppm)		
PA amount in final product stream (ppm)	49 (<300 ppm)		
Production rate (ton/day)	1105		

3. Increasing the daily production

With the target of production of 1380 ton/day AA, the new base was simulated by using old process configuration, i.e. all columns C-301, C-302 and C304 were utilized to obtain the requirement of product. For simulating the process, all columns were adjusted with the same recovery of acetic for each column and maximum flooding around 85%. Unfortunately, the results show that it is impossible to use the existing column sequence. The reason causing this problem is when increasing the throughput, of course the impurity amount is also increased. The columns C-301 and C-302 could not be well operated to remove the contaminants. Therefore, more impurity including FA, water and PA enters the refining column C-304. This causes not only the amount of FA in the final product stream 5522 ppm which is significantly higher than the requirement concentration in the product (must be less than 1000 ppm) but also the flood occurring in the column C-304, i.e. the column C-304 is bottlenecked. The retrofiting opportunity by replacing internals with new ones is excluded in this study when the columns are already being operated with highest performance internals.

4. Proposed method:

a)

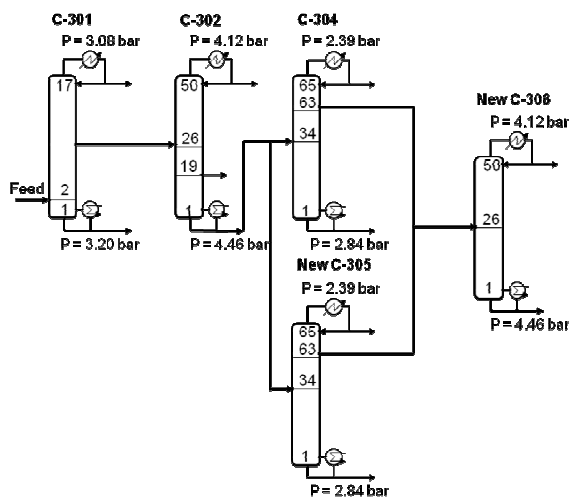

b)

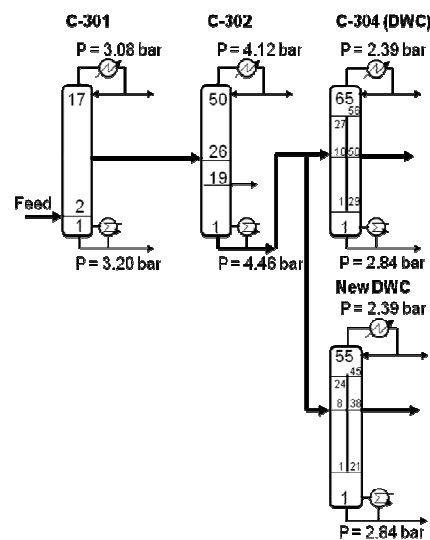

Figure 3. A simplified flow sheet illustrates the separation train showing (a) five of conventional columns including one new column added in parallel with column C-304 and another added in series and (b) two conventional distillation columns and two DWC systems including one from retrofiting of C-304 and one new DWC which is parallel with the column C-304.

For obtaining the requirement of product performance, the conventional column sequence is investigated which totally utilizes the old system. In order to increase the capacity of column, the max flooding of each column as well as acetic acid recovery need to be kept constant. Figure 3a shows the separation train involving five conventional columns which is applied to purify acetic acid from contaminants when the column C-304 is bottlenecked. Adding two new conventional distillation columns can be utilized for process debottlenecking; however it could not be preferred for saving energy and investment cost. Nevertheless, this case is considered as base case to evaluate the retrofiting efficiency.

In this part, the option which has the retrofiting the column C-304 to DWC and adding a new DWC in parallel with D-304, schematically drawn in Figure 3b, is also considered. Here, the existing column C-304 from the process can be retrofitting to a DWC to separate a part of the bottom stream of C-302; the remained flow is fed to the new DWC. The column C-304 is now modified by adding the wall in the middle section. The existing reboiler and condenser should be checked to know whether to be reused or not.

For retrofitting this column, the maximum flooding is fixed at 85%. The existing reboiler and condenser can be re-used because their duties are 19.87 and 20.40 Gcal/hr, respectively. Thus, only additional wall was counted for the retrofitting the column C-304 to DWC. By carrying out this case, the existing columns are maximally utilized, i.e. expenditure on new capital is minimized.

After the design and optimization procedure, the new DWC has 55 stages. Besides, the feed stage of DWC is the 8th stage and the divided wall is located from the 21st stage to the 45th stage while the side stream is drawn from the 38th stage. Here we assumed that all the columns have the efficiency of 100%. The duty of condenser and reboiler are 6.10 and 5.93 Gcal/hr, respectively. Retrofitting the column C-304 to DWC and adding one more new DWC can save 57.9% and 31.0% in terms of investment cost and energy consumption, respectively. The chemical/petrochemical plants usually have an annual maintenance period of 10–14 days, during which major repair and replacement are carried out. The retrofitting discussed above has been assumed to take place within this maintenance period, and so production loss during the retrofitting time has not been considered [4].

5. Conclusions

This paper has mainly considered the design of the DWC for removing the bottleneck phenomenon in the column when increasing the throughput of an existing distillation process. The DWC leads to significantly reduce investment cost and energy cost than the conventional distillation.

References

- [1] Hewitt, G., Quarini, J. and Morrell, M., More efficiency distillation, *Chem. Eng.* (1999).
- [2] Jane, J.H., The Cativa™ process for the manufacture of acetic acid, *Platinum Metals Review* **44**, 95-105 (2001).
- [3] PEP Report, “Acetic acid by low pressure carbonylation of methanol”, (1994).
- [4] Premkumar, R., Rangaiah, G.P., “Retrofitting conventional column systems to dividing wall columns, *Chem. Eng. Res. Des.*, **87**, 47-60 (2009).