

새로운 메조포러스 나노백금 / 탄소 복합체 합성, 특성 분석 및 응용

우성일, 최원춘¹, 전희중, 전민구

한국과학기술원 생명화학공학과 & 초미세 화학공정시스템 연구센터
(CUPS)

¹한국화학연구원

Table of contents

- Synthesis of Pt/Carbon Nano Composite
- Characterization of Pt/Carbon Nano Composite
- Application : Direct Methanol Fuel Cell

*Synthesis of Pt / Carbon
Nano Composite*

Characterization of SBA-15

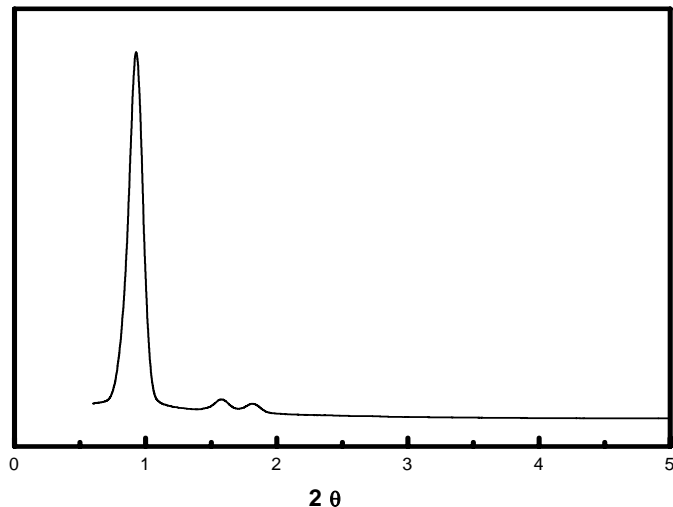

Small angle X-ray diffraction pattern

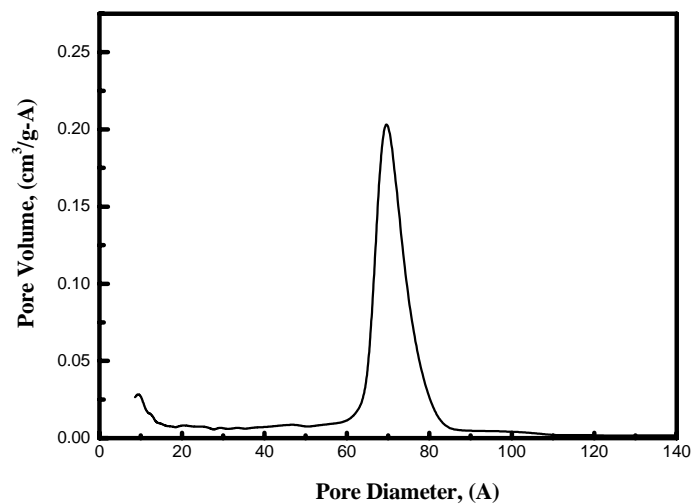

Pore size distribution

- XRD pattern
 - characteristic of highly ordered periodic material
 - 2-D hexagonal mesophase(space group p6mm)
 - indexed as (100), (110), and (200)
- Pore size distribution
 - exhibit a uniform mesopore size of 7.3nm
 - poor less than 3nm : interconnecting pore
- Brunauer–Emmett–Teller specific area
 - : 947.32 m²g⁻¹
- total pore volume : 1.23 cm³g⁻¹
- rope-like domains
 - : relatively uniform size of ~1μm

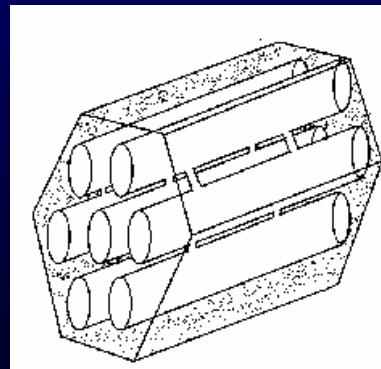

Mesoporous silica template
SBA-15

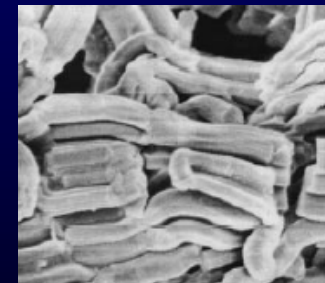

Science, Vol,279, Iss.23,
pp548–552,1998

Synthetic route: interconnected-composite rod array

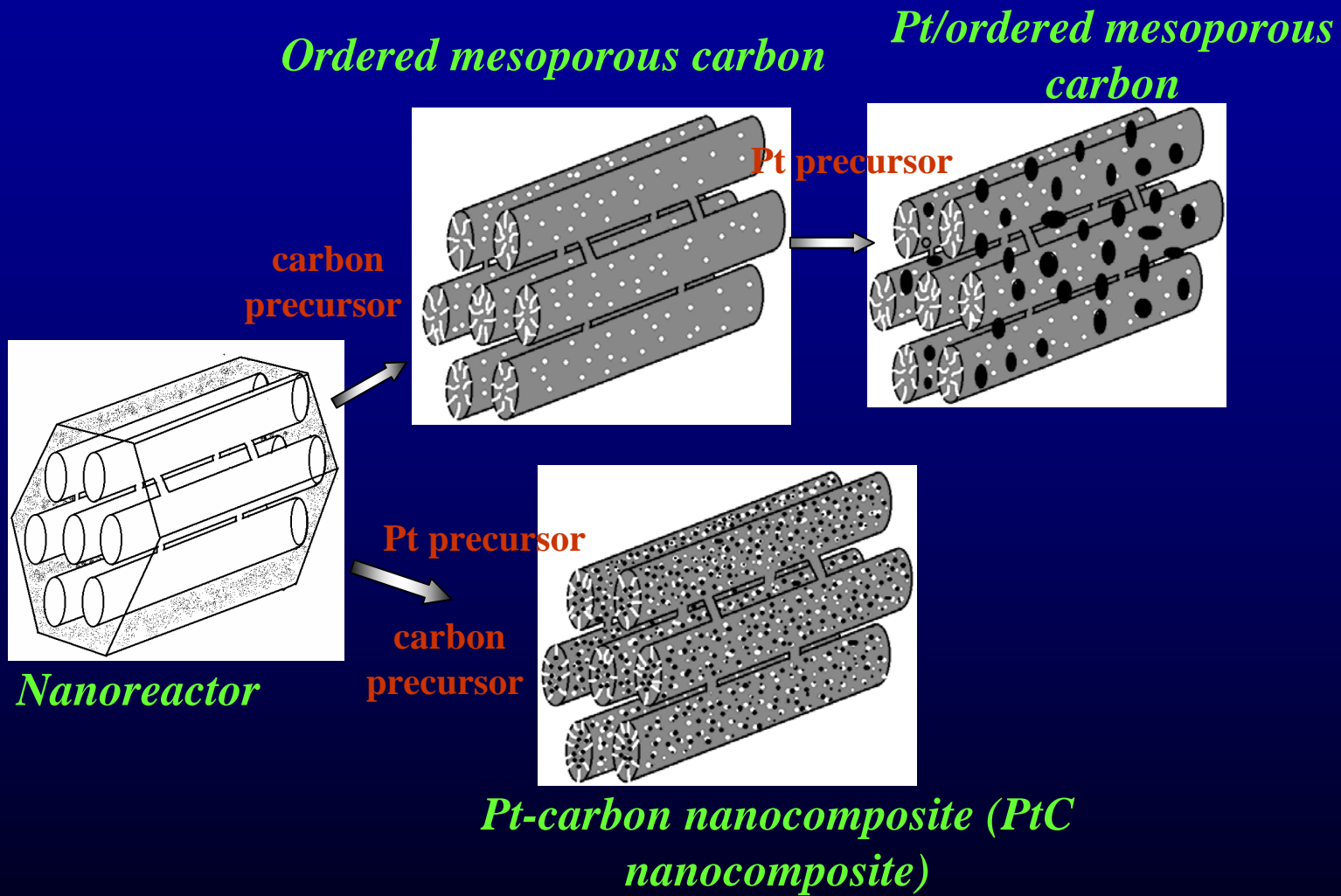

*Characterization of Pt / Carbon
Nano Composite*

Mesoporous PtC nanocomposite

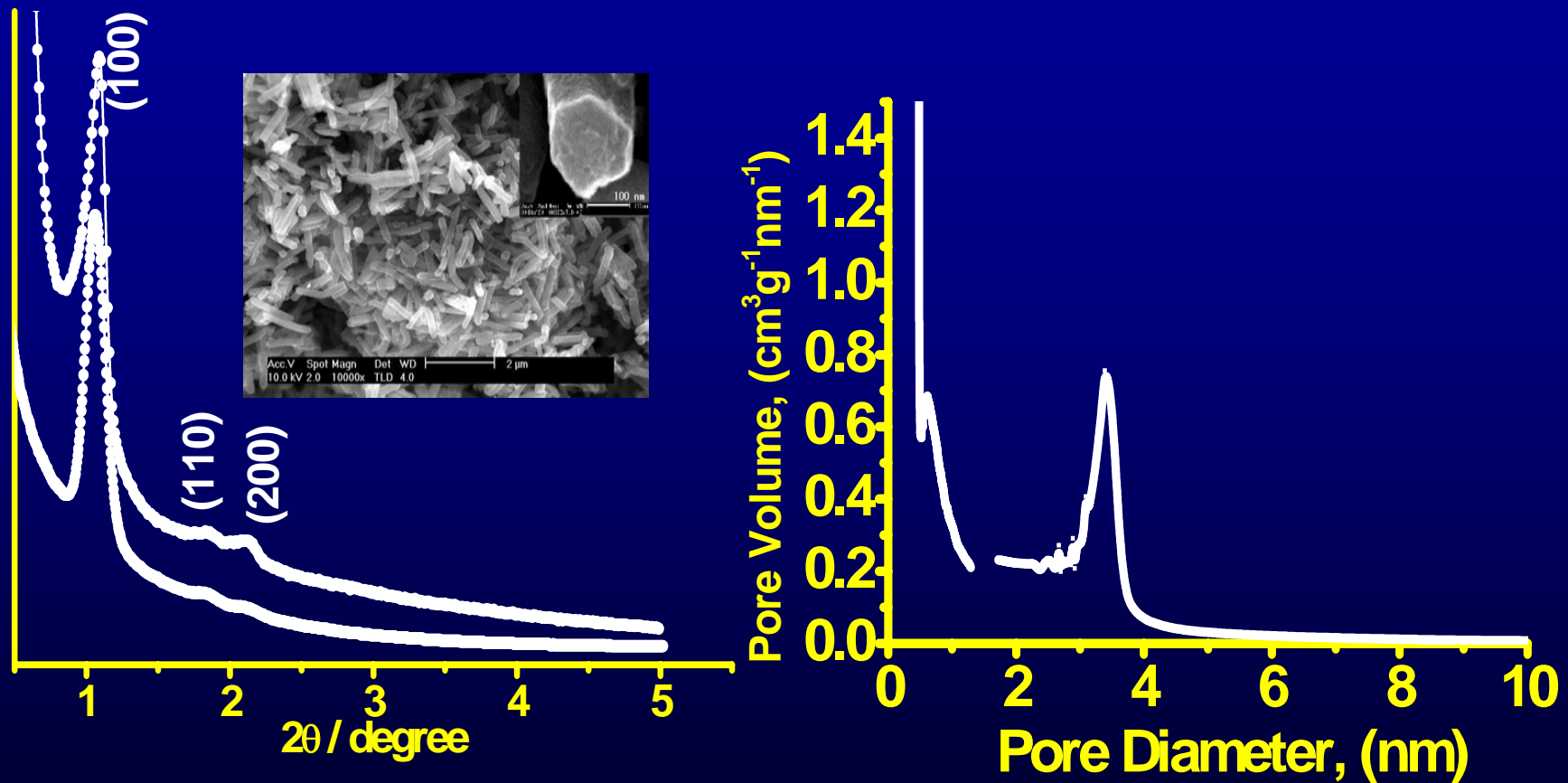

interconnected-composite rod array

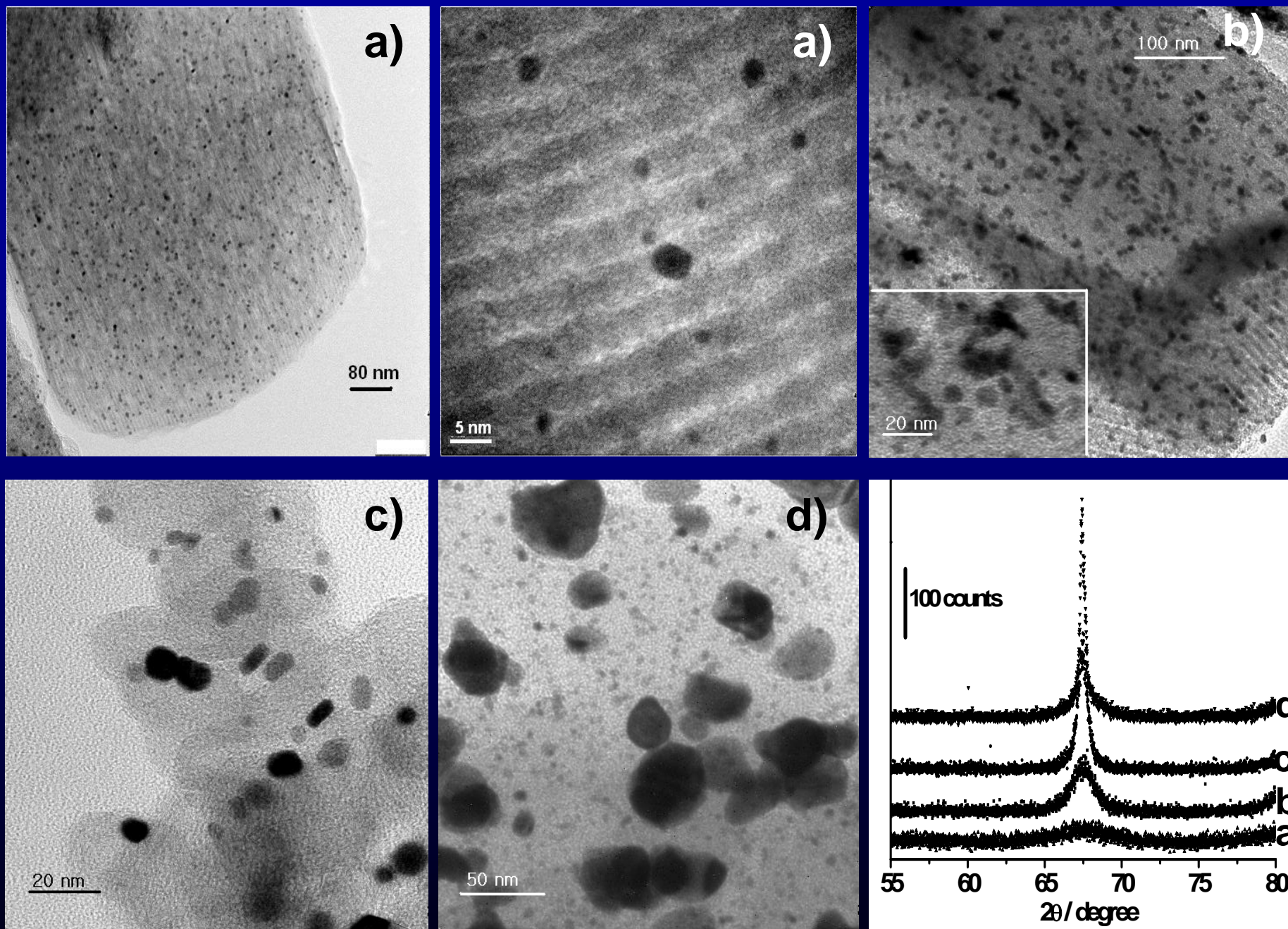

interconnected-composite rod array

Accessible Pt nanoparticles in micropores

- ✓ **Bromide solution**
: $\text{Br}_2 + (\text{C}_2\text{H}_5)_4\text{N}\cdot\text{Br} + \text{acetonitrile}$
- ✓ **Kinetic diameter of $(\text{C}_2\text{H}_5)_4\text{N}\cdot\text{Br}$, 0.8nm**
- ✓ **Dissolving Pt in mesopores or micropores (> 0.8nm)**

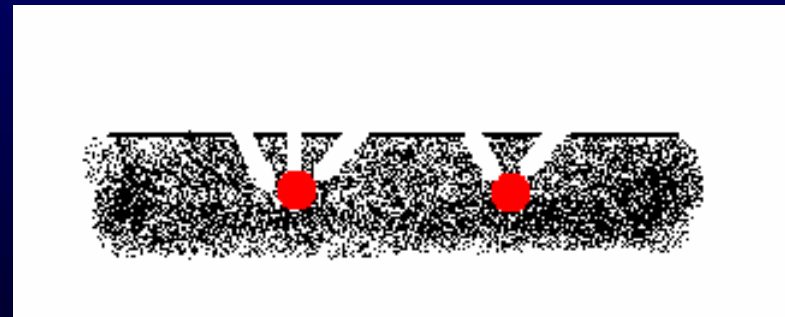
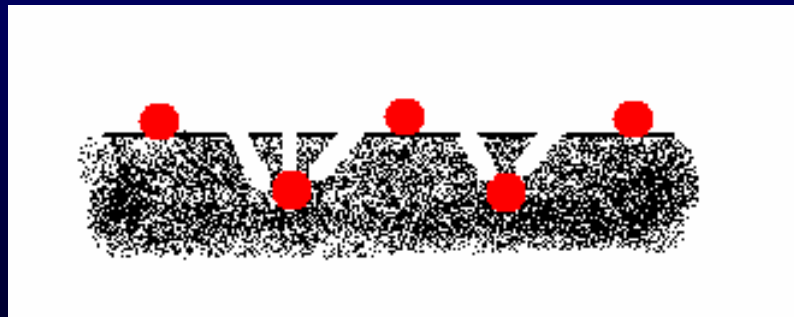

EXAFS analysis

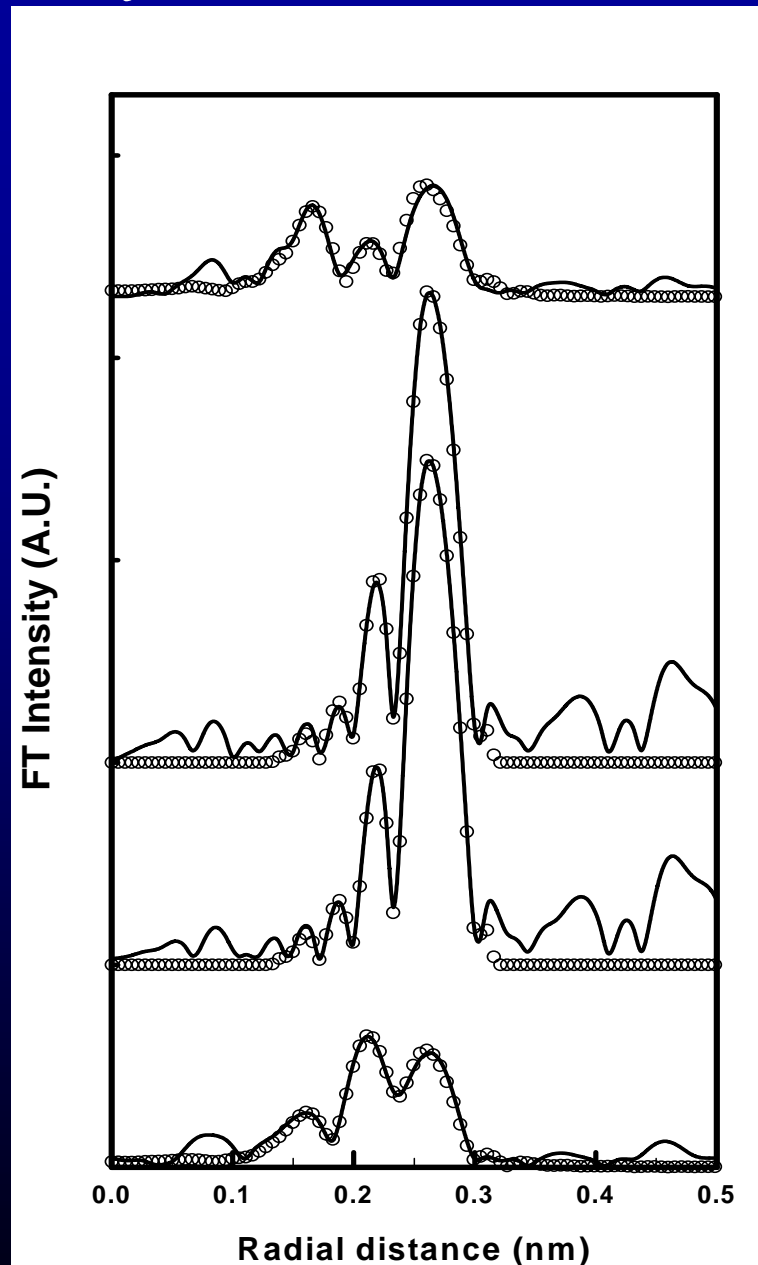

PtC nanocomposite
CN (Pt-Pt), 4.31
R (Pt-C), 0.204 nm

Pt/CMK-3
CN (Pt-Pt), 9.58

Pt/Vulcan
CN (Pt-Pt), 9.71

PtC nanocomposite (Br treatment)
CN (Pt-Pt), 2.78
R (Pt-C), 0.201 nm

interconnected-composite rod array

Structural parameters from EXAFS

Samples (Pt content, wt%)	Mass activity (A/g Pt)		Structural parameters*				
	0.96 V	0.76 V	Pair	CN	R (Å)	σ^2 (nm)	χ^2 (%)
PtCN arrays (24)	5.9	56.5	Pt-C	2.73±0.03	2.041±0.0008	48.9±1.6	13.8
			Pt-Pt	4.31±0.05	2.735±0.0006	73.5±0.9	
Pt/CMK-3 (24)	4.8	23.8	Pt-Pt	9.58±0.11	2.757±0.0004	50.1±0.1	4.2
Pt/Vulcan XC-72 (24)	4.8	22.6	Pt-Pt	9.71±0.03	2.757±0.0002	48.0±0.1	3.1
PtCN arrays treated with bromide solution (8.5)	13.8	80.9	Pt-C	2.12±0.03	2.014±0.0010	69.3±2.1	7.9
			Pt-Br	0.99±0.03	2.437±0.0005	38.4±1.7	
			Pt-Pt	2.78±0.005	2.736±0.0005	55.5±1.2	

FTIR analysis (CO adsorption)

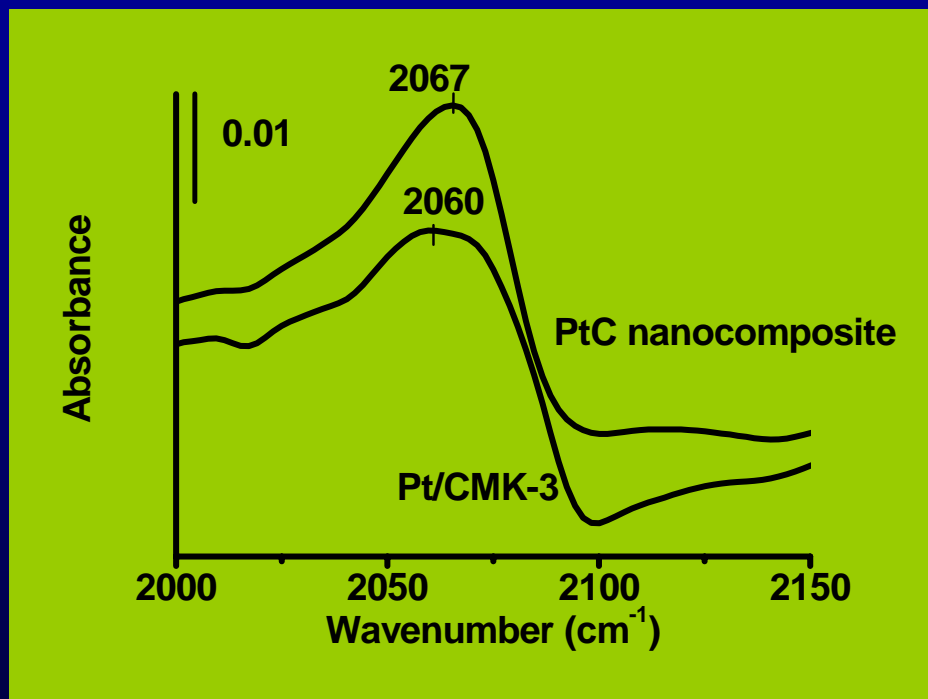

Before Br-treatment

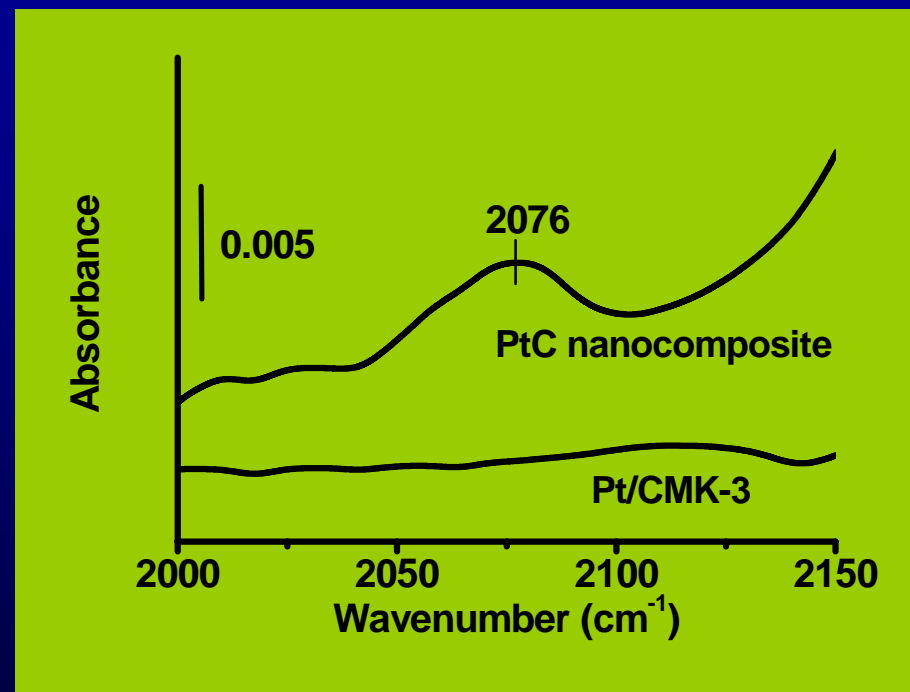

After Br-treatment

XPS analysis

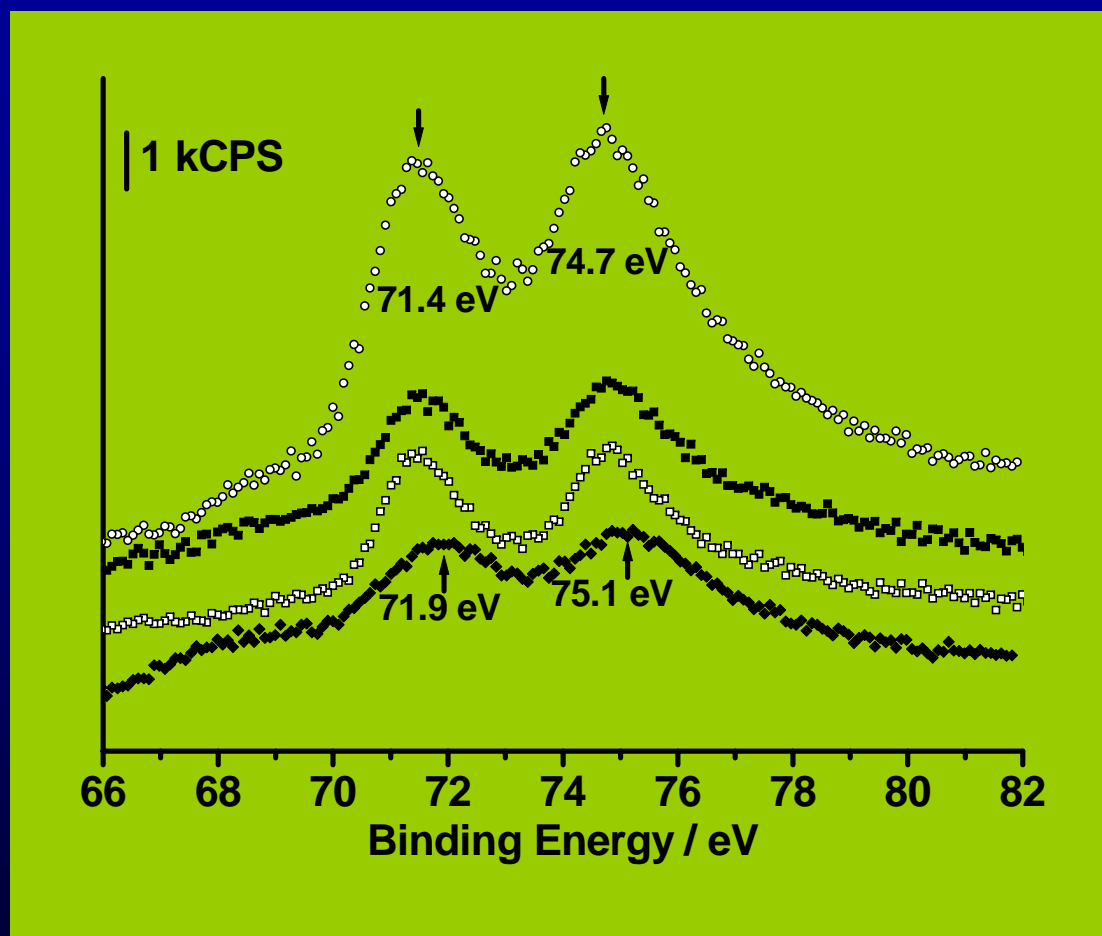

PtC nanocomposite

Pt/CMK-3

Pt/Vulcan

PtC nanocomposite
(Br treatment)

Stability of Pt-clusters in nano composite and commercial catalysis

12wt% Pt-CN

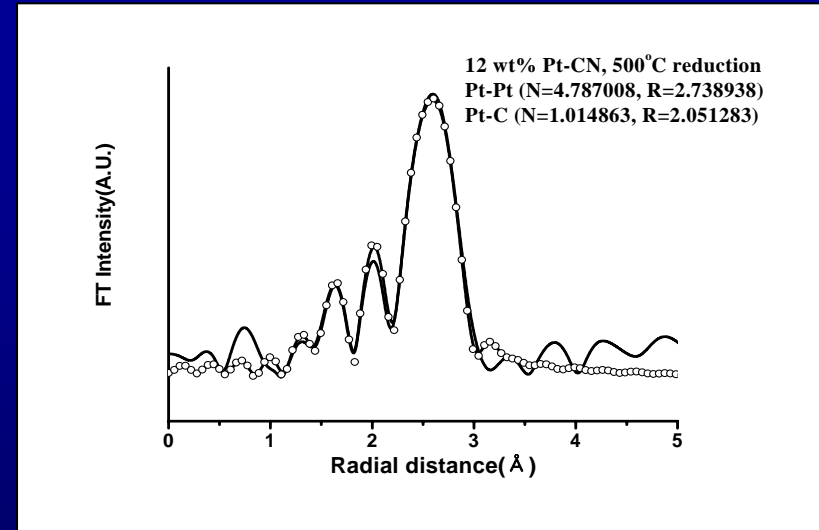
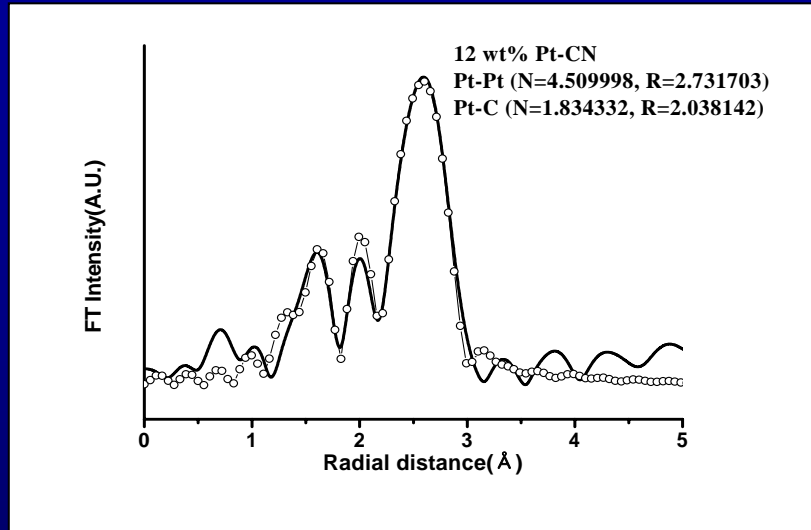

Commercial Pt/C (20 wt% Pt)

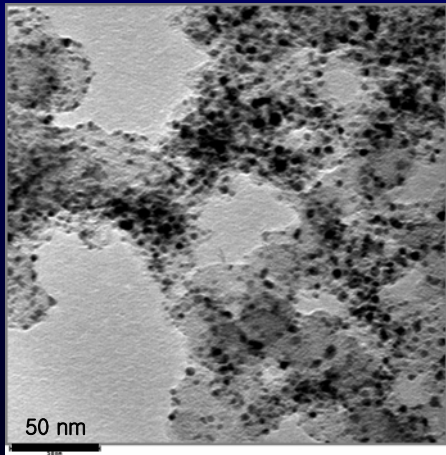

Before reduction
(Avg. Particle size 2~3nm)

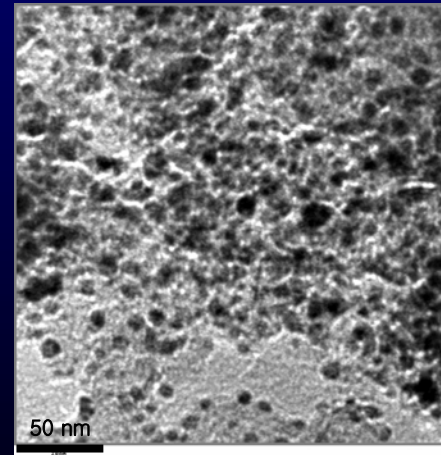

After reduction
(Avg. Particle size 6~7nm)

Application of Pt/Carbon nano composite :
Direct Methanol Fuel Cell (DMFC)

Electrochemical reaction of DMFC

1. Half-cell reaction for the anodic oxidation



2. Half-cell reaction for the cathodic reduction

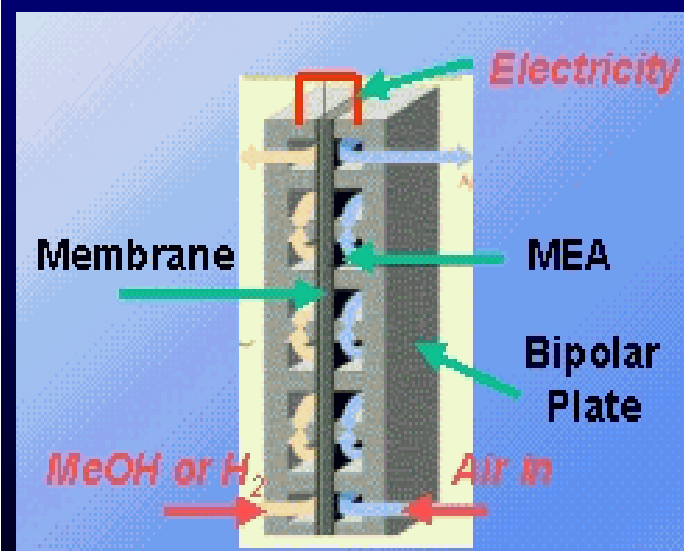
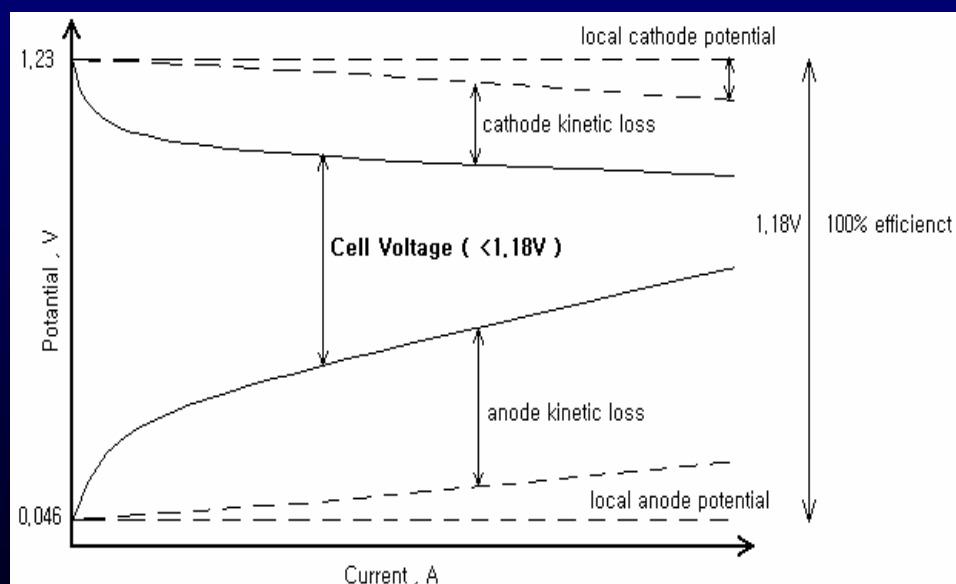

Methanol cross-over

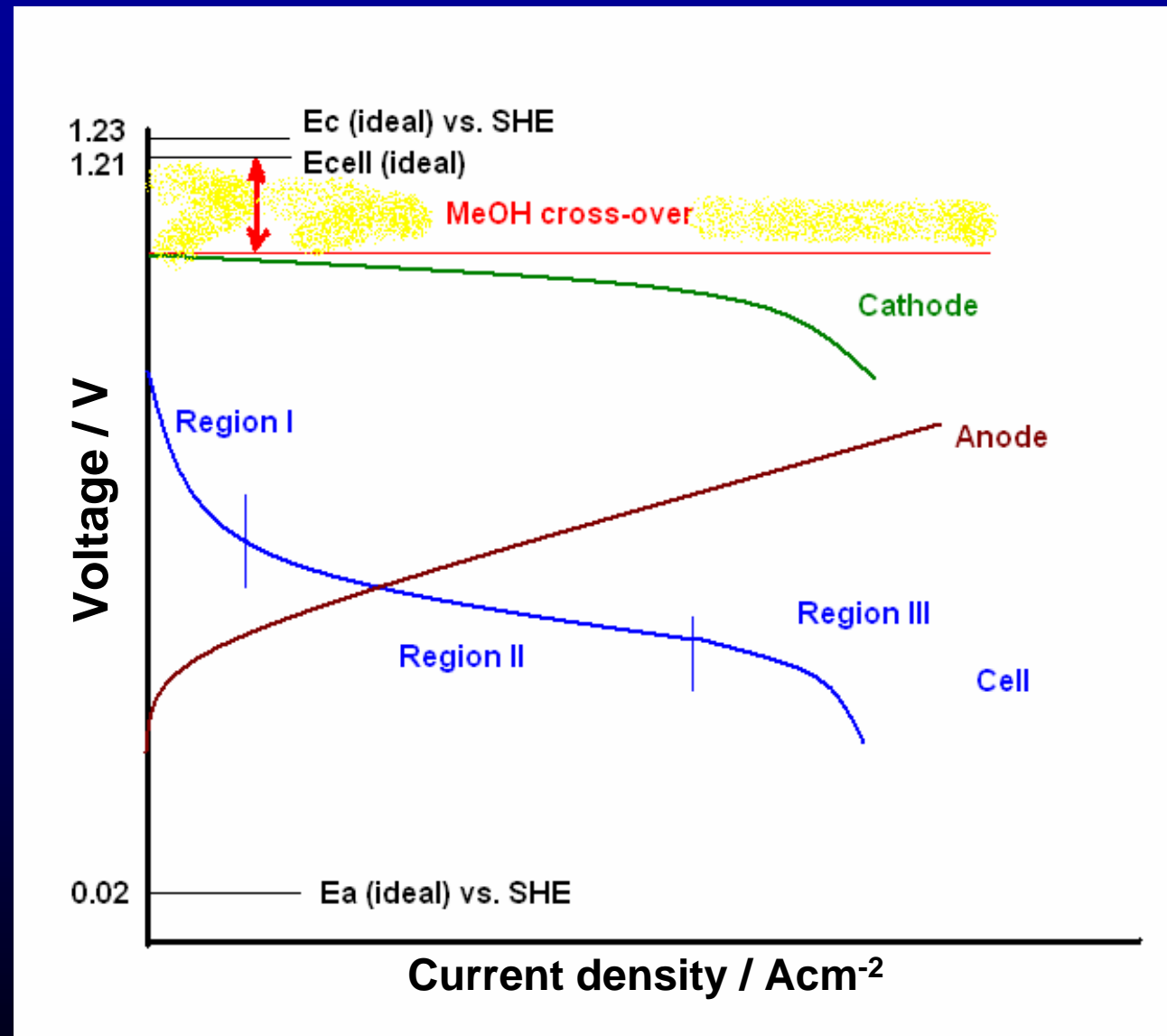

Pt particle size distribution

Fresh MEA

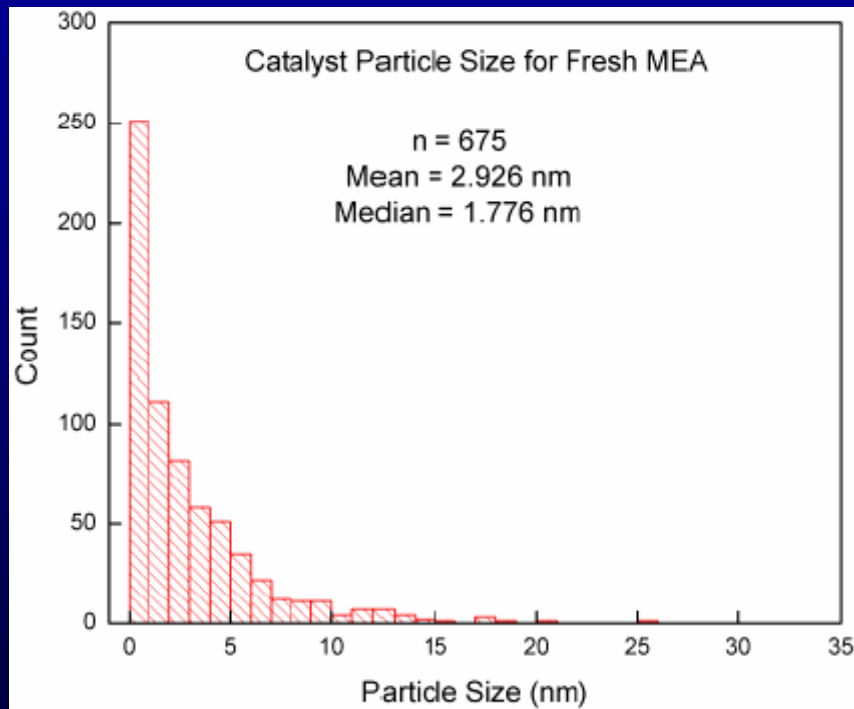

Failed MEA: Cathode

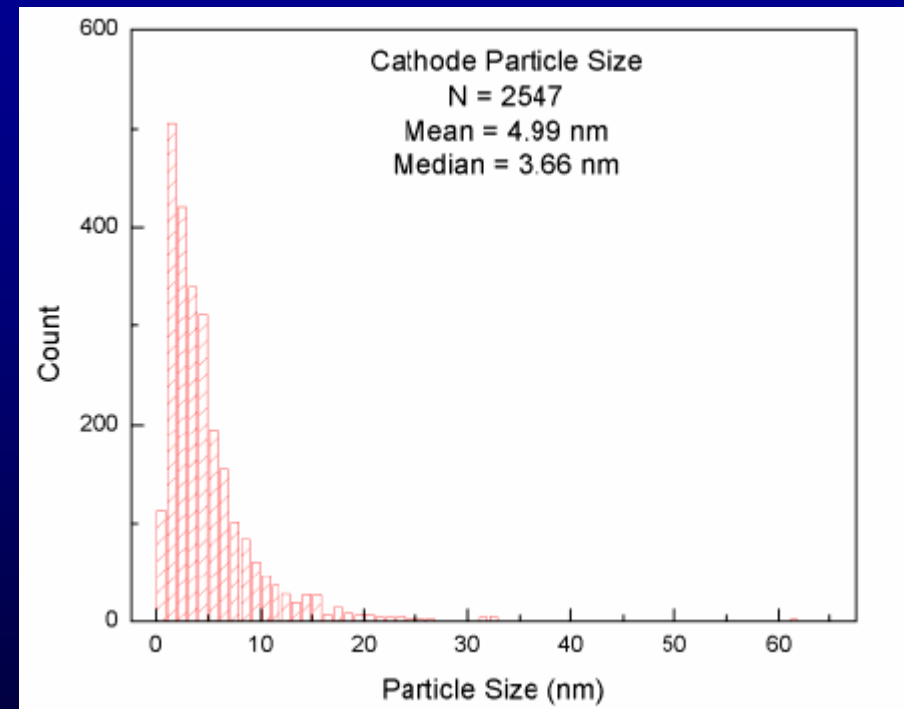

After 1200 hrs

OAK RIDGE NATIONAL LABORATORY
U. S. DEPARTMENT OF ENERGY

Approach in this study

- ✓ **Pt particle size vs. Pt(110) / [Pt(100) & Pt(111)]**
 - Pt(110), methanol oxidation
 - Pt(100) & Pt(111), oxygen reduction

Electrochimica Acta 36, 973 (1991)

J. Electrochem. Soc. 137, 845 (1990)

- ✓ **Studded Pt nano particles**
- ✓ **Micro pores only for oxygen diffusion**

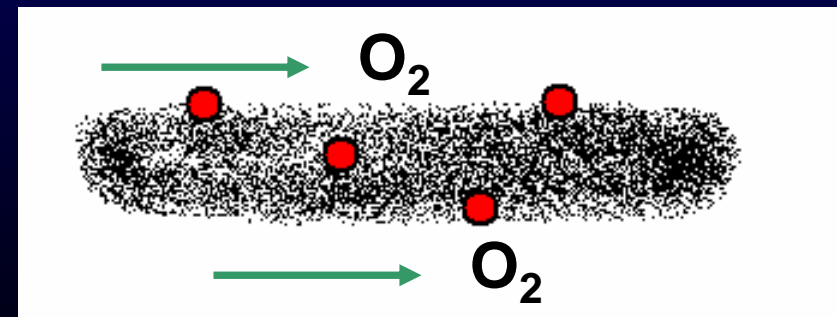
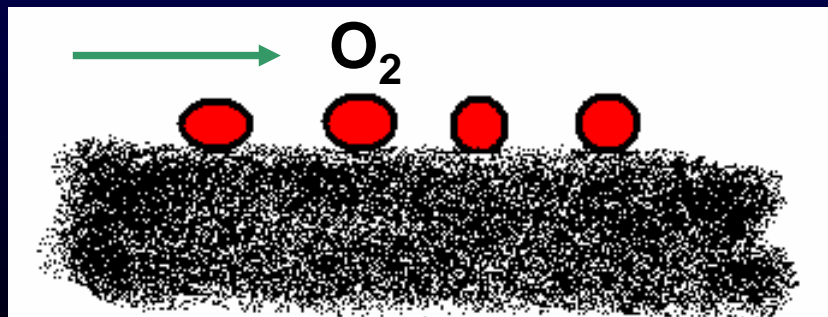

Oxygen electroreduction

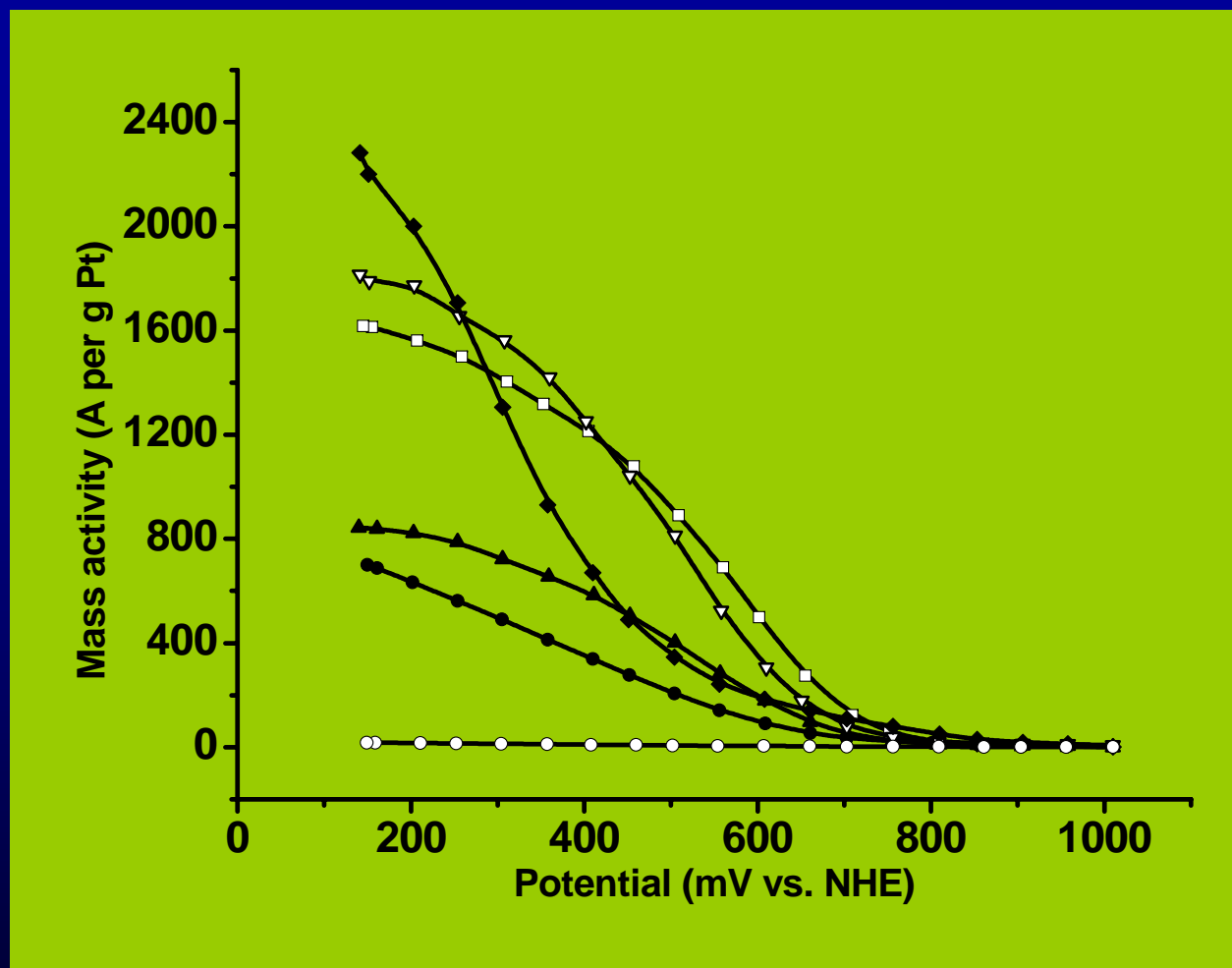

Electrocatalytic mass activity for oxygen reduction with Pt-carbon nanocomposite (12 wt% Pt) (▽), Pt-carbon nanocomposite arrays (24 wt% Pt) (□), Pt/CMK-3 (24 wt% Pt) (▲), Pt/Vulcan XC-72 (24 wt% Pt) (●) and Pt-carbon nanocomposite arrays (8.5 wt% Pt) (◆) and Pt/CMK-3 (○) after treatment with bromide solution.

Oxygen electroreduction mass activity

Samples (Pt content, wt%)	Mass activity (A/g Pt)		Structural parameters*				
	0.96 V	0.76 V	Pair	CN	R (Å)	σ^2 (nm)	χ^2 (%)
PtCN arrays (24)	5.9	56.5	Pt-C	2.73±0.03	2.041±0.0008	48.9±1.6	13.8
			Pt-Pt	4.31±0.05	2.735±0.0006	73.5±0.9	
Pt/CMK-3 (24)	4.8	23.8	Pt-Pt	9.58±0.11	2.757±0.0004	50.1±0.1	4.2
Pt/Vulcan XC-72 (24)	4.8	22.6	Pt-Pt	9.71±0.03	2.757±0.0002	48.0±0.1	3.1
PtCN arrays treated with bromide solution (8.5)	13.8	80.9	Pt-C	2.12±0.03	2.014±0.0010	69.3±2.1	7.9
			Pt-Br	0.99±0.03	2.437±0.0005	38.4±1.7	
			Pt-Pt	2.78±0.005	2.736±0.0005	55.5±1.2	

Methanol-tolerant PtC nano composite (I)

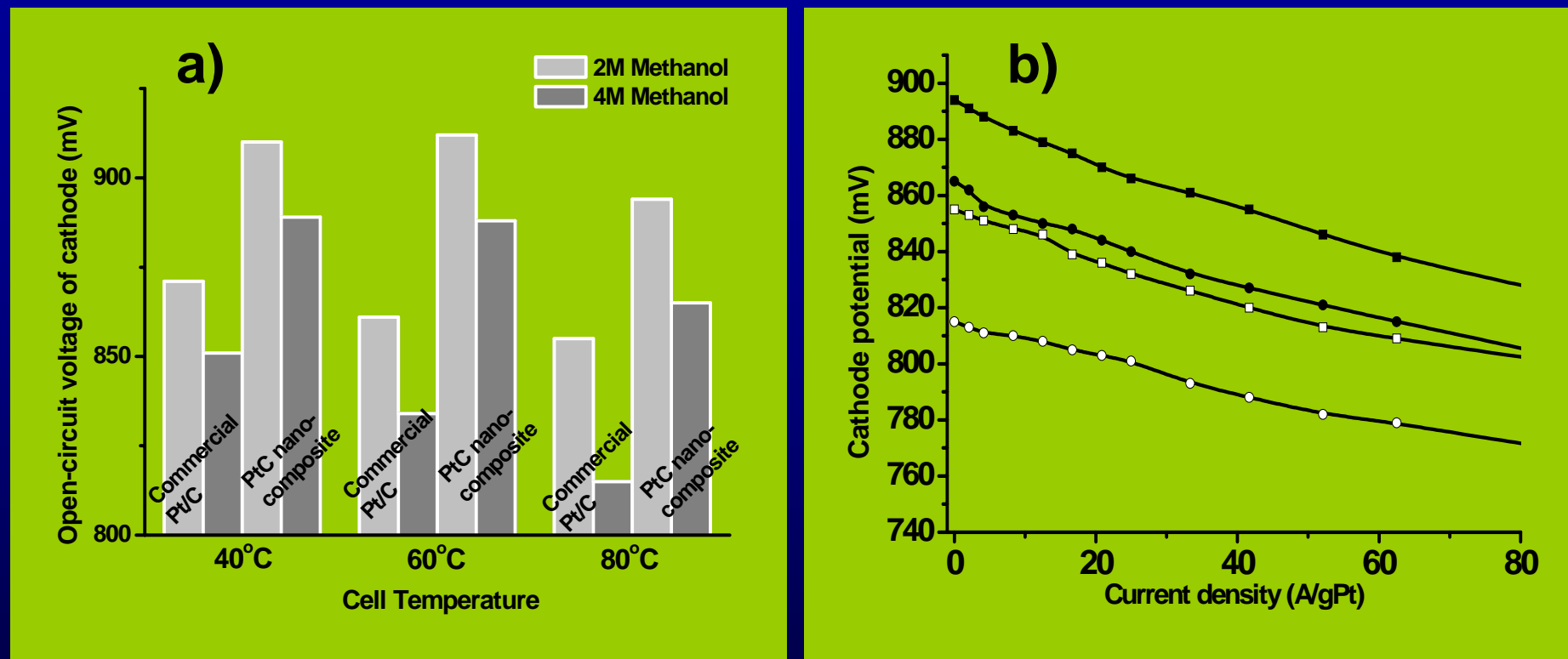

Open-circuit voltages of cathode (a) at various cell temperature and methanol concentration at anode and polarization curves of cathode (b) for DMFC at 80°C using commercial 20 wt% Pt/C (EC-20-PTC, empty) and 24% PtC nano composite (filled) with 2M (squares) and 4M (circles) methanol solution.

Methanol-tolerant PtC nano composite (II)

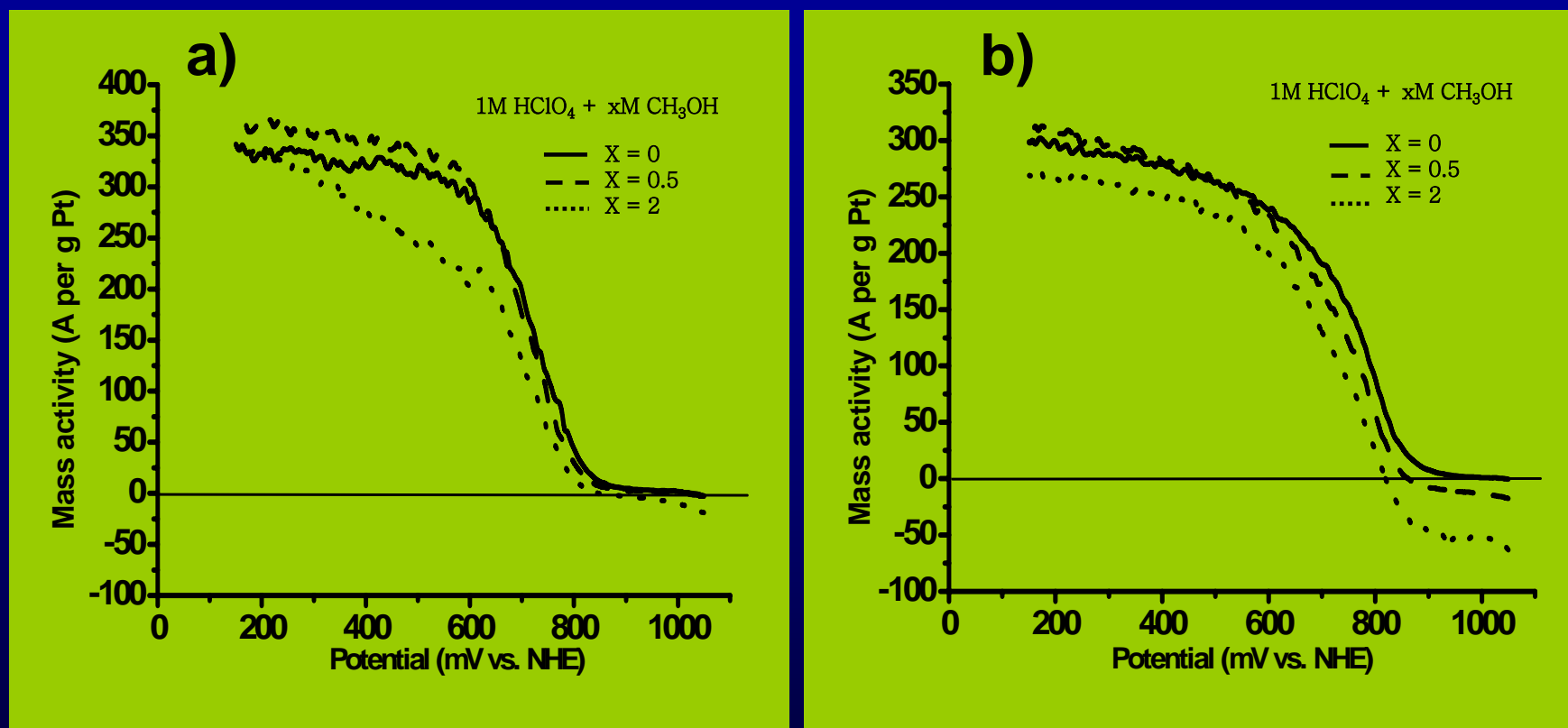

Electrocatalytic mass activity of 12 wt% PtC nano composite (a) and commercial 20 wt% Pt/C (Electrochem, Inc., EC-20-PTC) (b) for the oxygen reduction in oxygen-saturated 1M HClO₄ with xM CH₃OH (x = 0, 0.5 and 2).

Conclusions

- ✓ **New mesoporous PtC nanocomposite**
- ✓ **Highly microporous PtC nanocomposite**
- ✓ **Electrocatalytic active Pt in micropores**
- ✓ **Ultrafine Pt clusters with narrow size distribution**
- ✓ **Methanol-tolerant PtC nanocomposite**